

# Self-Tuned PID Based Speed Control of BLDC Motor

Anuradha S. Muley<sup>1</sup>, R. M. Autee<sup>2</sup>

<sup>1</sup>Student, Department of Electronics and Telecommunication, Devgiri college of Engineering, Aurangabad, India

<sup>2</sup>Professor, Dept. of Electronics and Telecommunication, Devgiri college of Engineering, Aurangabad, India

**Abstract:** Brushless DC Motors (BLDCM) have found immense applications in automobile, automation, consumer electronics, medical and industrial applications due to their high efficiency, long operating life ratio of torque delivered to the size and fast dynamic response. In a brushless motor, the rotor incorporates the magnets, and the stator contains the windings. Commutation is implemented electronically with electronic speed controller (ESC) which uses the semiconductor switches to change current in the windings based on the motor back EMF. PID controller is designed in MATLAB Simulink software and PID gains are tuned using auto tuning method. Digital PID controller is then implemented on FPGA as it provides greater flexibility and higher resources for implementing control algorithms. FPGA (PID controller) receives back EMF output from BLDC motor and generates the gate pulses which drive the switches of electronic speed controller. Actual speed of the motor is compared with the reference speed given and the error signal is processed in a PID controller to obtain the required pulse width. As the motor rotates, feedback (back EMF) signals are produced in accordance with rotor position. Three phase voltages are produced from ESC after they receive the decoded signals. These voltages are fed as input to the motor and it rotates at required speed.

**Keywords:** Brushless DC motor (BLDCM), Electronic speed controller (ESC), FPGA, MATLAB Simulink software PID controllers.

## 1. Introduction

Latest advance in permanent magnet materials, solid state devices and microelectronic have resulted in new energy efficient drives using permanent magnet brushless DC motors. Brushless DC motors are very popular in a wide array of applications in industries such as appliances, automotive, aerospace, consumer, medical, industrial automation for its reliability, high efficiency, high power density, low maintenance requirements, lower weight and low cost. As the name implies, BLDC motor do not have brushes for commutation. Instead they are electronically commutated. BLDC motor have many advantages over brushed DC motor and induction motors, like better speed- torque characteristics, high dynamic response, high efficiency, noiseless operation and wide speed ranges. Torque to weight ratio is higher enabling it to be used in applications where space and weight are critical factor.

A BLDC motor finds numerous applications in motion

control. A BLDC motor has windings on stator and alternate permanent magnets on rotor. Electronic commutation of stator windings is based on rotor position with respect to the stator winding. A new generation of microcontrollers and advanced electronics has overcome the challenge of implementing required control functions, making the BLDC motor more practical for a wide range of uses.

BLDC motors have many advantages over conventional DC motors like: i) long operating life, ii) high dynamic response, iii) high efficiency iv) better speed vs. torque characteristics v) noiseless operation vi) higher speed range vii) higher torque-weight ratio.

BLDC motors have many advantages over brushed DC motors and induction motors. The brushless dc motor is gaining popularity because of its usage in computers, aerospace, military and robots. For the same input power, a BLDC motor converts more electrical power into mechanical power than a brushed motor due to the absence of friction due to brushes.

It uses permanent magnet as rotor and an electronic controller is required to continuously switch the phase of the winding which will keep the motor spinning. For accomplishing it a feedback sensor and power electronics switching circuit is required. Control strategies for three-phase BLDC machines are typically implemented using a power converter. To generate appropriate control signals to perform the desired function, a special-purpose processor or a programmable logic device is usually necessary. Even though special purpose controllers are developing faster, they should be simpler, efficient and cost effective. The Field Programmable Gate Array (FPGA) features are growing vertically every day. Latest powerful FPGA devices could be used in BLDC drives. The speed of the motor is directly proportional to the applied voltage. By varying the average voltage across the windings, the speed can be altered. Since commutation is provided with the help of electronic switches, the duty cycle is controlled by using PWM signals.

Because there is no mechanical or electrical contact between the stator and rotor of the BLDC motor, alternative arrangements are required to indicate the relative positions of the component parts in order to facilitate motor control. BLDC motors use one of two methods to achieve this, either employing Hall sensors or measuring back EMF. We have used sensor less BLDC motor in the proposed system. Sensors

motors work well, but add cost, increase complexity (due the additional wiring), and reduce reliability (due in part to the sensor connectors that are prone to contamination from dirt and humidity). Sensor less control addresses these drawbacks. The sensor less BLDC motor working is based on the back EMF principle.

### 2. Mathematical modeling of BLDC motor

Modeling of a BLDC motor can be developed in the similar manner as a three phase synchronous machine. Since its rotor is mounted with a permanent magnet, some dynamic characteristics are different. Flux linkage from the rotor is dependent upon the magnet. Therefore, saturation of magnetic flux linkage is typical for this kind of motors. As any typical three phase motors, one structure of the BLDC motor is fed by a three phase voltage source as shown in Figure 3.4. The source is not necessary to be sinusoidal. Square wave or other wave-shape can be applied as long as the peak voltage is not exceeded the maximum voltage limit of the motor. Similarly, the model of the armature winding for the BLDC motor is expressed as follows.

$$V_a = R i_a + L \frac{d i_a}{dt} + e_a \quad (1)$$

$$V_b = R i_b + L \frac{d i_b}{dt} + e_b \quad (2)$$

$$V_c = R i_c + L \frac{d i_c}{dt} + e_c \quad (3)$$

or in matrix form as follows:

$$\begin{pmatrix} V_a \\ V_b \\ V_c \end{pmatrix} = \begin{pmatrix} R+pL & 0 & 0 \\ 0 & R+pL & 0 \\ 0 & 0 & R+pL \end{pmatrix} \begin{pmatrix} i_a \\ i_b \\ i_c \end{pmatrix} + \begin{pmatrix} e_a \\ e_b \\ e_c \end{pmatrix}$$

Where,

- La=Lb=Lc=Ls=M
- Ls= Armature self-inductance
- M= Mutual inductance
- Ra=Rb=Rc=R= Armature resistance in Ohm
- Va,Vb,Vc= Terminal phase voltage in volts
- ia, ib, ic= motor phase currents in Amperes
- ea, eb, ec= Back emf in volts
- P represents d/dt in the matrix

Due to the permanent magnet mounted on the rotor, its back emf is trapezoidal. The expression of back emf must be modified as expressed in:

$$e_a(t) = K_E * \vartheta(\theta) * \omega(t) \quad (5)$$

$$e_b(t) = K_E * \vartheta(\theta - 2\pi/3) * \omega(t) \quad (6)$$

$$e_c(t) = K_E * \vartheta(\theta + 2\pi/3) * \omega(t) \quad (7)$$

Where KE is the back emf constant and  $\omega$  is the mechanical speed of the rotor.

The permanent magnet also influences produced torques due to the trapezoidal flux linkage. Given that KT is the torque constant. The produced torques:

$$T_E = (e_a i_a + e_b i_b + e_c i_c) / \omega \quad (8)$$

The resultant torque, TE, can be obtained by the following expression:

$$T_a(t) = K_T * \vartheta(\theta) * i_a(t) \quad (9)$$

$$T_b(t) = K_T * \vartheta(\theta - 2\pi/3) * i_b(t) \quad (10)$$

$$T_c(t) = K_T * \vartheta(\theta + 2\pi/3) * i_c(t) \quad (11)$$

$$T_E(t) = T_a(t) + T_b(t) + T_c(t) \quad (12)$$

With the Newton's second law of motion, the angular motion of the rotor can be written as follows:

$$T_E(t) - T_L(t) = J \frac{d\omega(t)}{dt} + B * \omega(t) \quad (13)$$

Where

- TL load torque is in N-m
- J rotor inertia in [kgm<sup>2</sup>]
- B damping constant

### 3. Proposed system

In this proposed system, the PID controller is designed on MATLAB SIMULINK software and the PID gains are tuned using auto tuned principle. The PID controller is then implemented on Spartan FPGA. When the load is applied across the BLDC motor, the PID controller calculates the error signal/speed as difference between the measured and actual speed. The controller then works on this errors signal and gives the output (PWM) signal to Electronic speed controller (motor driver) which drives the motor at desired speed.

Brushless dc (BLDC) motor drives are continually gaining popularity in motion control applications. Therefore, it is necessary to have a low cost, but effective BLDC motor speed/torque controller. There are various controllers/ controlling techniques available to obtain smooth speed control of the motor. In the proposed system a PID controller is designed to control a speed of 1000KV brushless DC motor. The PID model of brushless DC motor is designed with MATLAB SIMULINK software and then the PID architecture is implemented on FPGA. Tuning the parameters of a PID controller is very important in PID control. In this system the parameters of PID controller are tuned using auto tuning principle which has the capabilities to track different set point. The proportional, integral and derivate gains of PID controller are tuned online to force the system to follow the specified reference (point/track). The performance of the BLDC motor under 3 different resistive load conditions is observed and the percentage of speed at specific load is displayed on seven segment display. The proposed PID control technique gives a good speed regulation/tracking regardless the presence of external disturbances and/or parameter variations.

The 30A Electronic speed controller (ESC) is powered up using 12V 2A DC voltage source. DC ESCs in the broader sense are PWM controllers for BLDC motor. The ESC accepts a nominal 50 Hz PWM servo input signal whose pulse width varies from 1 ms to 2 ms. when supplied with a 1 ms width pulse at 50 Hz, the ESC responds by turning off the BLDC motor attached to its output. This is known as stall or breaking condition of the motor. When presented with 2.0 ms input

signal, the motor runs at full speed.

Initially when power supply is switched on, the motor will only beep until we provide an ESC 1ms duty cycle PWM signal. As soon as we provide the 1ms signal to ESC the motor will stop beeping and enters into breaking/stall condition. The motor will have 0% speed in this condition. When the first load (LED) is applied across the motor the actual speed of the motor changes. The auto tuned PID controller designed on the FPGA forces the motor to run at this new speed.

The analog output voltage generated across the load is given to ADC which converts this voltage to 8 bit digital voltage and is then fed back to FPGA (PID controller). This is now referred as new desired/actual speed of the motor. The PID controller then calculates the error signal and automatically tunes its parameters to generate an output signal (PWM signal). This PWM signal is then fed to the ESC which drives the motor at desired speed. This completes the closed loop control system of the BLDC motor drive. The dynamo in the system acts as a DC generator which converts the 3 phase motor output to direct current for LEDs/ load circuitry. In the proposed system the performance of the BLDC motor is observed under three different load conditions and percentage of motor speed at particular load condition is displayed on seven segment display on FPGA development board.

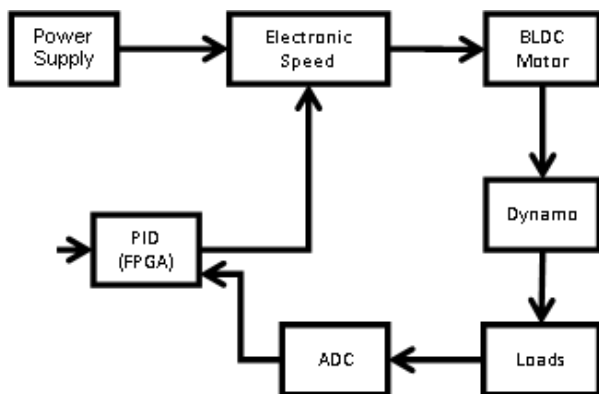

Fig. 1. Block diagram of proposed system

#### 4. Performance analysis

Here I am giving some of the performance result findings at initial stage of system. After modeling, the tuned gain parameters of PID controller shows step response with the proposed system as shown in Fig. 2.

The PID controller then automatically tunes its parameters ( $K_p$ ,  $K_i$  and  $K_d$ ) and forces the motor to run at the actual speed.

To initiate the feedback loop, a PWM signal of at least 1ms duty cycle is applied to ESC. When the first load applied across the motor and the auto tuned PID mode is switched on, the PID controller applies the auto tuning algorithm and calculates the Proportional ( $K_p$ ), Integral ( $K_i$ ) and Derivative ( $K_d$ ) gains of the system to get an ideal response from the system.

In auto tuning method the PID controller calculate the gains just once and then initiates the closed loop system based on

these gain parameters.

With the auto tuning method the gain parameters are found as:

Table 1  
PID gains using auto tuning method

Proportional gain	$K_p$	360
Integral gain	$K_i$	2
Derivative gain	$K_d$	830

The step response of the ideal system at auto tuned PID gains is shown below:

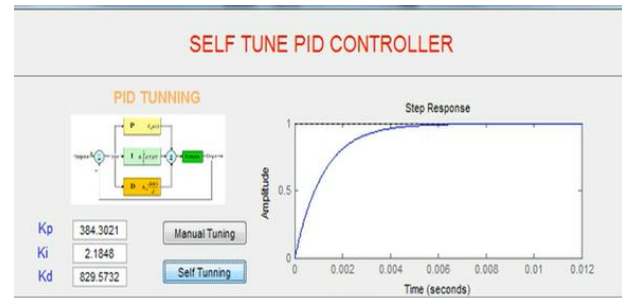

Fig. 2. Step response of the proposed system at auto tuned PID gain parameters

As shown in the Fig. 2, the overshoot value of the system becomes 0,  $ess=0$  (steady state error) and  $t_s=4ms$ . With these parameters of P-I-D controller, we have obtained the system design requirements.

#### 5. Conclusion

Here I am giving some of the findings of my proposed system as conclusion as BLDC have better speed versus torque characteristics, high dynamic response, high efficiency, long operating life, noiseless operation, higher speed ranges, rugged construction and so on. Also, torque delivered to the motor size is higher, making it useful in applications where space and weight are critical factors.

In this proposed system, the PID controller is designed to control speed of brushless DC motor. The designed PID controller has both manual and auto tuning options. The controller is designed on MATLAB Simulink software and then implemented on FPGA. In this model the speed control of BLDC motor is based on digital PWM principle. It is observed that as the load on the motor increases the duty cycle of PWM signal increases. The PID controller generates the varying voltage PWM signal under varying load conditions to rotate the motor at desired speed. According to the experiment done it is observed that, when the set speed is changed (when load is applied), the motor speed locks to the set speed, when the current error becomes zero.

#### Acknowledgement

The Project report is an important in the field of engineering studies and to make this event successful, it is very necessary to have the guidance of experienced people. It is beyond my word

power to acknowledge for seminar guidance to those who have helped me to complete this project report in such a presentable manner. But as a matter of tradition I have tried to express it in my simple words.

I would humbly like to thank my project guide and HOD Dr. R.M Autee for his guidance and scholarly advice imparted throughout this project report. Without his help it would not have been possible to reach at this stage of my report.

Also I am extremely thankful to my respected Director Dr. Ulhas Shiurkar for his motivation, inspiration and co-operation towards completion of my project report. Last but not the least I am very grateful to my ME co-ordinator Prof. A. R. Wadhekar for her kind suport.

### **References**

- [1] Rubaai A., "Experimental Verification of a Hybrid Fuzzy Control Strategy for a High Performance Brushless DC Drive System", IEEE transaction on Industry Applications, vol. 37, issue- 2, Mar/Apr 2001, pp 503-512.J.S.
- [2] SUN Li-Jun, "Study on PWM Modulation Mode of BLDC Motor", Journal of Harbin University of Science and Technology.
- [3] Mehdi Nasari, "A PSO Based Optimum Design of PID Controller for a Linear Brushless DC Motor", International Journal of Electrical, Robotics, Electronics and Communication Engineering, vol. 1, issue 2,
- [4] Tinga Shi, "A New Approach of Minimizing Commutation Torque Ripple for BLDC Motor Based on DC-DC Inverter", IEEE transactions on Industrial Electronics, vol. 57, issue 10, Dec 2009.
- [5] P. Devendra, "Microcontroller Based Speed Control of Three Phase BLDC Motor", JERS, vol. 2, issue 4, Dec 2011, pp 68-
- [6] C. Ganesh, "ANN Based PID Controlled BLDC Drive System", Conference on Advances in Electrical and Electronics", 2011.