

Intelligent Defense RC Machine

Yasmeen Khan¹, Akash Gupta², Rahul Jaiswal³, Sanjay Sahani⁴

^{1,2,3,4}BE Student, Department of Electronics, Shree L. R. Tiwari College of Engineering, Mumbai, India

Abstract: The military forces tried to use new arms and weapons for reducing the risk of their lives and to save their nation from terrorism. With the advancement in technology, it mostly depends on the high tech weapons or machinery being used. Robotics is one of the trending fields of modern age in which the nations are focusing on making use of military forces in war and to maintain peace worldwide. Here in this project we aim on designing a remote controlled robot using RF which can be used by soldiers at the war field. This will reduce the risk of losing their lives. The robot will have live video surveillance by which it can record the data of its surrounding in real time. Live warnings can also be given by the soldier with the help of audio system. The robot will have the shooting mechanism through which it can shoot the enemy approaching towards it. The soldier will be able to aim by looking in live video through the laser placed in robot which is also movable by 360° in horizontal direction and 90° in vertical direction along with gun and camera. Speed of robot can be varied by varying the PWM signal so that the input voltage of DC motors can vary. A switch will be present to turn the light on and off if necessary. This project will therefore be used for military purposes and hence it will result in forming a strong part of army for our country.

Keywords: Remote controlled (RC), Radio frequency (RF) Pulse width modulation (PWM), Global positioning system (GPS), System on chip (SOC).

1. Introduction

Military robots or intelligent defense machine are autonomous robots or remote-controlled (RC) mobile robots designed for military applications for rescue and attack in war. Some such machines are being used, and many are under development. The utilization of Robotics in military is well shown by US and Russian army. Osama and other terrorists were caught by these military machines. They are strong and they are daring, they don't have fear of death and they have helped in Iraq and Afghanistan wars. In today's world terrorists are terrified by drone and aerial attacks. The use of robotics technology in military lead to a new field in robotics i.e. Military Robotics. Military robotics isn't about forming an army of robots but utilization of robotics technology for fighting terrorism and defending the nation thus saving soldier's lives. Therefore, it's not necessary that military robots have to be humanoids or they have to carry weapons or arms instead they are just those robots which can help the armed forces in war. The range of up gradation offered by these technologies are endless. There are many machines already developed which are being used in military forces like Foster Miller, 21st Century Robotics, Northrop Grumman, General

atomics etc. They have created many job opportunities and are developing in this sector. Future of robotics is something which can be prove to be a boon or bane depending on the application. In today world military robots use very complex and advanced technology for different applications. They use different technologies for scouting, exploring, guidance and weaponry. Mostly GPS, Fibre optic cables, LIDAR etc. are being used for transmission and receiving. GPS is used for satellite connection which are used in mobile phones. Fibre optic is highly advanced and robust in communication. LIDAR is based on laser communication technology and is used in applications for detecting the speed of vehicles by traffic police. For scouting purpose technologies being used are electronic RF sensors, camera, RADAR etc. The machines can also carry weapons which are dangerous to handle by humans without any fear. They can also supply ammo or other supplies to the soldiers during war time at battle field. So using robotics in military helps to increase the strength of the army as well as the nation is more secured.

2. Motivation and background

The concept of robot army isn't a present day concept. The introduction of military robots started from 1898 by the introduction of radio boats by. It was observed by many researchers in the last century. They were used by Germans and Russians in Second World War. Russians used Teletanks in their army and Goliath were used by Germans in war. The Teletanks were used with DT machine guns, flamethrowers and smoke container to provide a smokescreen to the enemy. The turning point in history was making use of Goliath which is a mobile landmine. And today the development in this technology is well demonstrated by military robots in countries such as Afghanistan and Iraq. At present the most commonly used military robot is the unmanned aerial vehicle IAI Pioneer and RQ-1 Predator. One of the greatest threat is that in every science fiction movie, it's seen that robots have gone out of control and started harming us. Actually, in real life it is practically impossible. The developers have taken care of this thing while designing. Most of the military robots are controlled with remotes by humans. And in case if the machine has got out of control then there is a reset button which clear there memory and the machine can again come back to normal state. With the help of artificial intelligence we can design a machine which can have decision taking ability on its own.

3. Objectives

The main objective of this project is to implement a defense machine which will be helpful for soldiers during war time. It will be controlled by soldiers and they could also monitor its action in real time. The machine can move right or left according to the command given. This project is better than various existing machines as it includes many features such as mars rover mechanism, speed control circuit, live audio warning and many more to go. As soldiers risk their lives to save the nation there are about more than 2000 deaths during war time. But if we make use of remote controlled machines then there will be no risk to soldier's life. These robots don't need any medical help or they can't get injured. Also they can be controlled by humans and reach to any destination during war time for inspection. They can warn the enemies by live video and audio surveillance and can travel easily on terrains due to mars rover mechanism. Though there are many advanced technologies which is existing in real world to make the robots self-controlled but then too for present the most economical way to introduce defense machines in our country is by making use of remote controls as it is the first and most primary step to make the army modernized.

4. Problem statement

A. Problems with recent technologies

1) Speed control mechanism

In recent technologies there is no speed control mechanism included. Due to this the machine works at constant speed which is not desirable in all situations. Over these past ten years the computer designers have aimed in incorporation of the military robots in war and defense. The advantage of using these robot machines is that they are more accurate and reliable whereas humans are slow and there's chances of inaccuracy because of human errors. The military strength of the army will be increased and their power will be also more. So there's still a problem with some machines that there is no speed control mechanism.

2) Wheels

The wheels used were of tank tread mechanism which made the vehicle run on terrains but its speed is less as compared to other wheels which can't run on terrains with high speed. The main disadvantage of tank tread mechanism is that they have low speed, complex mechanism, and short life and are easily damaged. Also even if any one of the segment of track get dislocated from its position then its overall working will be affected. Sometimes if the track is jammed then there's a chance of it being damaged and it may happen that it's too late to repair it.

3) Warn intruders

There is no way to warn the intruders so that they could surrender at the last moment. There should be one module of audio and video so that the enemies be beware and find hard to escape.

B. How to overcome the problems

1) Speed control mechanism

Speed control mechanism is included which helps to vary the speed according to the requirement. Motors provide AC speed control motors, brushless DC speed control motors and inverter unit's thus giving wide range of it in speed control systems. An efficient speed control can be achieved by taking into consideration some important factors such as function, performance, cost and the purpose for designing the system. Motor will be designed by following the product development cycle so that it can offer various range of speed.

2) Mars rover mechanism

The speed efficiency is increased with the help of mars rover mechanism which is able to run on terrains without resisting the speed. This mechanism makes use of six wheels each having a motor. The front and rear wheels also have single steering motors individually. This steering unit makes the machine to turn full 360 degrees round. The four steering wheels helps the rover to move across the curves and rocky planes enabling it to move smoothly over the terrains. The maximum angle it can offer is about 65 degrees. However researches are going on to increase its angle so that it can cross about more than 65 degree obstacle coming across its path. The most important thing when designing suspension is to look into the fact that the system should be able to change its position dramatically when crossing a rocky path.



Fig. 1. Wheels using mars rover mechanism

3) Live audio and video surveillance

Live audio and video is also present to keep an eye on each activity of the intruder and to warn them from staying at farther distance. Long range shooting is also possible due to video surveillance. The camera can move in both right and left direction with the help of joystick. Live video will be able to view the scenes from far away which can't be seen with naked eyes. The video will be displayed as well as recorded at the same time. Recorded video will help to repeat telecast the scenes and monitor it again if required.

5. Block diagram

A. Transmitter

- **Power supply:** It is used to supply power to all the component.
- **Control unit:** It is used to control the direction and speed control of the motor by transmitting the signal through the transmitter.
- **Microphone:** It is used to send voice warning messages using transmitter.
- **Display:** It is used to receive the video signal from the camera which is placed on our machine.

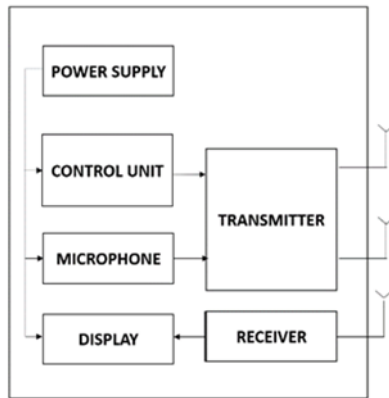

Fig. 2. Transmitter side

B. Receiver

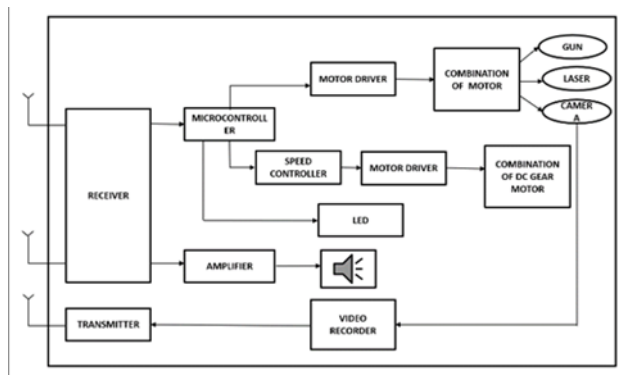

Fig. 2. Receiver side

Here the transmitted signal is received from the remote control (transmitter side). The signal is received to the respective pin of the receiver which is further given to the microcontroller or amplifier.

- *Amplifier*: It is used to amplify the voice signal and send to speaker as output.

- *Microcontroller*: It is used to control different types of motor based on the application with the help of motor driver viz. DC gear motor which is the wheel part of our project.
- *Camera*: It is used to send live video signal to the receiver via transmitter.

6. Conclusion

This study therefore concludes that if we make use of intelligent machines in our military system, then our army can stand along with other powerful countries. In spite of having 2nd largest military force our nation ranks 5th in case of power even though USA and Russia has less number of soldiers if compared with India and the reason behind that is unmanned military machine. This project can be used by our nation for defense and attacking purpose. Also these machines don't require any medical treatment so no need of immediate treatment to be done hence saving soldiers life. The audio and video feature added to it makes it more efficient for soldiers to take actions against the enemy. Also the overall long distant visions are also clearly visible. This machine can travel at any uneven surface due to mars rover mechanism added to its wheels. So if this project is implemented in our army forces then it will come out to be a boon for our nation.

References

- [1] 'Radio Frequency Based Automatic Control of Electrical Load' by M. Narayanan, M. Ashok Kumar A. Ranjith Kumar, K. Raja Info Institute of Engineering, Coimbatore, Tamil Nadu, India 15th Feb. 2017.
- [2] 'Wireless Speed and Direction Control of DC Motor by using Radio Frequency Technology' by Ankesh N. Nichat, Sheikh Kadir Ali, Yogesh D. Solanke, Amit M. Dodke Dept. of Electrical Engineering And Amravati University, DES's COET, Dhamangaon Railway Maharashtra 2nd, Feb 2015.
- [3] 'Real Time Wireless Surveillance System with Motion Detection and Device Control over Internet' by Munyaradzi Rushambwe, Tinashe Chamunorwa, Kumbirayi Nyachionjeka Harare Institute of Technology, Harare, Zimbabwe 3rd March 2016.
- [4] 'Research on a Remote Control Vehicle' by liu huan, wang dhau, zhang tong, huang keming. IEEE, 2010.