

Secured Smart Healthcare Monitoring System Based on IoT

A. Sudarsan¹, M. Lavasai Anveesh²

^{1,2}Student, Dept. of Electronics and Communications, SRM Institute of Science and Technology, Chennai, India

Abstract—Now-a-days technology plays a major role in healthcare not only for sensory devices but also in recording and display device and also in communication. It's important to monitor various medical parameters and post operational days. Hence the latest trend using IOT in Healthcare communication method is adapted. Internet of things serves as a catalyst and plays major role in wide range of healthcare applications. In this project the ATMEGA8 microcontroller is used to communicate to the various sensors such as temperature sensor and pulseoximeter sensor. Microcontroller picks up the sensor data and sends it to the webpage and hence provides real time monitoring of the health care parameters for doctors and data can be accessed anytime by the doctor. Controller is also connected with buzzer to alert the caretaker about variation in sensor output. The major issue in remote patient monitoring system is that the data as to be securely transmitted to the destination end and provision is made to access the data is allowed only for authorized user. The security issue is been addressed by transmitting the data through the Keyword which will be encrypted by standard Msg91 and the users/doctor can access the data by logging to the html webpage. During the time of extremity situation through GSM module connected to the controller, alert message is sent to the doctor. Hence provisional medication can be done by this system and it is efficient with low power consumption capability, high performance and time to time response.

Index Terms— Smart Healthcare Monitoring, IoT

I. INTRODUCTION

Internet is very important part in our daily life. Internet has changed how people live, work, play and learn. It serves for much purpose finance, educations, Business, Entertainment, Industries, Shopping, Social Networking, E-Commerce etc. Internet of Things (IOT) is the next new mega trend of Internet. This is visualizing a world where several objects can sense, communicate, share information over a Private Internet Protocol (IP). The objects which are interconnected collect the data at regular intervals, analyze and used to initiate required action, providing an intelligent network for analyzing, planning and decision making. This is Internet of Things (IOT) world. It is generally considered as connecting objects to the Internet and using that connection for control and remote monitoring of those objects. This definition was only a part of IOT evolution considering the machine to machine market today. Actual definition of IOT is creating a brilliant invisible network which can be controlled and programmed through internet. Products developed based on IOT including embedded technology which

allows them to exchange information among each other or the Internet and it is assumed that around 8 to 50 billion devices would be connected by the end of 2020. Since these devices come online, they provide better life style, create safer, more engaged communities and revolutionized healthcare. This entire concept of IOT stands on wireless network, sensors and gateway, which enables user to communicate and access the application/information consequently add to an IOT framework which gives secure health awareness checking. So outlining a savvy medicinal services framework where client information will get from sensor and sent to the web browser through Msg91 and permitting just approved clients to get to the information.

A. Problem Definition

A patient who stays in home during post operational days checking is done either via overseer/ medical caretaker. On the grounds that anything can change in wellbeing parameter inside of part of seconds and amid that time if guardian/attendant is not in the premises causes more noteworthy harm so ceaseless observing may not be accomplished by this system. With this innovation which created a period where web administers the world gives a thought to add to another keen health awareness framework where all the time constant checking of the patient is accomplished.

B. Existing System

In the Existing System we are measuring the health parameters of the patient and we are sending these parameters through the Zigbee, Bluetooth Communication protocol. These protocols have short communication ranges to transmit the data. Whenever the doctor is in remote place the health parameters can't send to the doctor. To overcome this we had a solution by transmitting the data through the webpage.

C. Proposed System

The main idea of this system is to continuous monitoring of the patients over internet. The Proposed System IOT Healthcare architecture is as shown in the Figure.1 the model consists of ATMEGA8 Microcontroller, Temperature sensor (LM35), Pulseoximeter Sensor (TCRT1000), Liquid Crystal Display (16x2), GSM MODEM, Electric Buzzer and Regulated Power Supply. In this system ATMEGA8 Microcontroller collects the data from the sensors and sends the data to Web page. The

Protected data sent which can be accessed anytime by the doctors by typing the corresponding unique URL address in any of the Internet Browser at the end user device.

D. Flowchart

The flow of the project as follows:

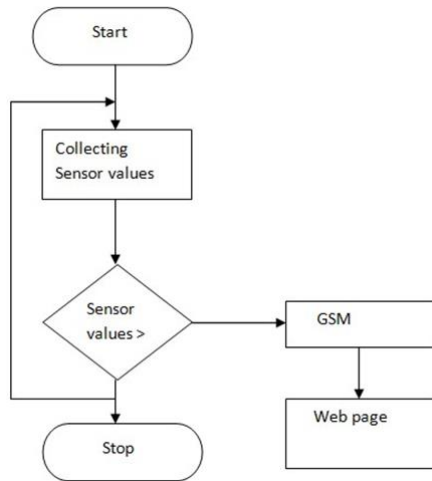

Fig. 1. Flowchart diagram

If any sensor values get goes high it will send a message from GSM to the webpage through the gateway and displayed in the webpage and the process will continue as shown in the flow chart.

II. ARCHITECTURE OF HEALTH MONITORING SYSTEM

Module consist of different sensors like

- ECG: connected to body which gives different pulse rate, weather healthy or not.
- Bed Wet: Gives weather Patient Bed is wet or not.
- Temperature: work like thermometer gives body temperature.
- GSM Module: Send a message to the authorized person.
- Buzzer: To give a beep sound for indication.

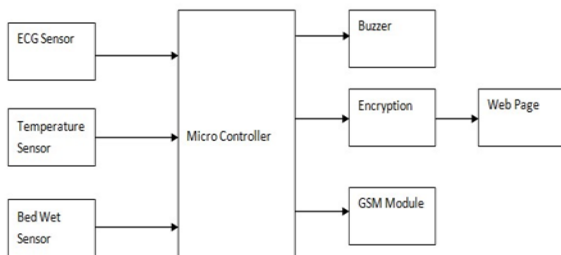

Fig. 2. Block diagram

A. AVR Microcontroller

Features:

- High-performance, Low-power, Atmel 8-bit Microcontroller

- Advanced RISC Architecture
 - On-chip 2-cycle Multiplier
 - 130 Powerful Instructions– Most Singleclock Cycle Execution
- Special Microcontroller Features
 - Power-on Reset and Programmable Brownout Detection
 - External and Internal Interrupt Sources
 - Internal Calibrated RC Oscillator

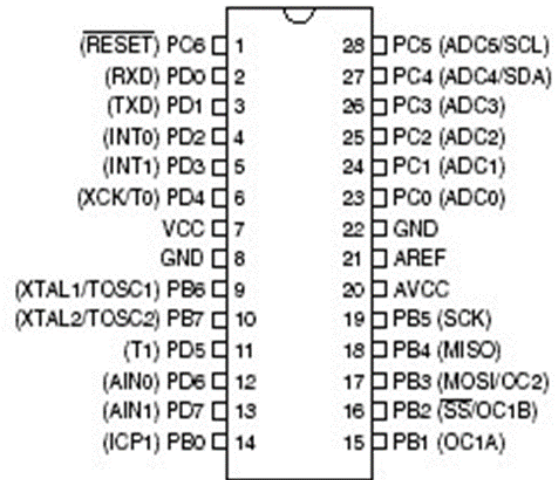

Fig. 3. Pin diagram of AVR

B. Pressure Sensor

Several different pressure sensors from different suppliers were examined for this task. The following features were favorable when choosing pressure sensor:

- Pressure range, from -10 to 10 mbar.
- Large resolution, full scale span of at least 1024 counts.
- Large repeatability and high accuracy (< 2:5%).
- Working on a 3V system.
- Using an interface that exist on the microcontroller, either analogue, TWI (I2C), □ SPI or parallel data transfer.
- Relatively low price, < 700 NOK for large quanta.
- Sampling frequency of at least 100 Hz.
- Low power consumption and start-up time.

Three pressure sensors were selected for further work, the ASDX-series from Honeywell and the LDE and HDI series from Sensor techniques. The sensor from Honeywell was discarded because they could not deliver one with the correct pressure range within reasonable time. After testing the LDE series it too was discarded because their maximum pressure range only went to _5 mbar, slightly lower than what was considered as the lower limit of pressure span. The final sensor, HDI, met all specifications. It could run on either 3V or 5V, had both digital (I2C) and analogue interface, a pressure range from 10 mbar up to 1000 mbar, accuracy of 0.5% (prime grade) or

1.5% (high grade). The ATMEGA2560 provide both I2C (albeit they have adopted their own standard, called Two Wire Interface) and ADC (Analogue to Digital Converter) interface. Since the pressure sensor could output a full scale span of 21,845 counts when using the digital interface, but the ATMEGA2560 had only 10 bit ADC resolution, resulting in 1024 counts, the digital interface was chosen.

1) *Schematic of the pressure sensor circuit*

The schematic of the pressure sensor circuit is shown in figure 4. It is a very simple connection, where the ground is connected directly to pin 3. Vcc is connected to pin 1 in parallel with a 0.1uF capacitor connected to ground to remove ripple that may occur when heavy loads are drawn from the C. The two wires of the I2C interface, SDA and SCL are connected to pin 4 and 6, respectively. Not shown in this circuit are the two pull-up resistors that have to be connected from the signal lines to Vcc in order to pull the signals high, according to the way the I2C interface operate. Note that Vcc is not connected directly to the battery, but via the microcontroller. This enables the system to power on and off the pressure sensor when required, conserving battery power.

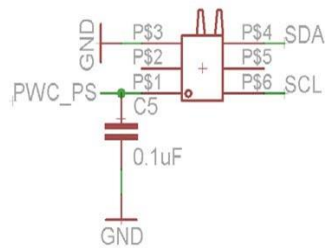

Fig. 4. Schematic of pressure sensor

C. *Bed Wet Sensor*



Fig. 5. Bed wet sensor

Common childhood problem is bedwetting that will have a significant impact on child’s health if it left unattended. At night times, parents will not know if the child has urinated and the kid may sleep all night on the wet bed or with a wet nappy’s. Bed wet alert system provides a very effective solution to this problem, by sounding an alarm as soon as the child began to wet the bed. Bedwetting alarm is one of the widely recognized and most effective solutions for bedwetting. It’s a safe and it has no potential side effects like medical treatment.

D. *Gateway*

Like Internet Forums, a gateway is a link between two computer programs or systems. This gateway acts as a portal

between two programs letting them to share information by communicating between protocols on a computer or between dissimilar computers. Gateway is also known as application proxy or application-level proxy, an application gateway is an application program that runs on a system between two networks. When a client program establishes a connection to a destination service it connects to an application gateway. In order to communicate with the destination service, the client then negotiates with the proxy server. The proxy establishes the connection with the destination behind the firewall and acts on behalf of the client hiding, protecting individual computers on the network behind the firewall. This creates two connections one between the proxy server and the destination and one between the client and the proxy server. All packet-forwarding decisions are made after connecting the proxy. Since all communication is conducted through the proxy server the computers behind the firewall are protected.

In our Project we have used a gateway called MSG91 which provides a message and Email

Notification to the authorized person. The messages are passed through the GSM module and the Information is displayed in the web page by using a Keyword which the user need to define and the callback Url will generate with that call back URL the user can browse anywhere from the Laptops or Mobile Phones.

The Gateway is MSG91 which will provide a virtual Number. By using that virtual Number we can send the Message to the user as well to the Webpage.



Fig. 6. Msg91 flow diagram

III. HARDWARE AND SOFTWARE DESCRIPTION

A. *Pressure Sensor*

Key part in implementation of a spirometer is a transducer to convert the air flow into an electrical signal, which can be processed by an electronic mean. To achieve this, the MED I2C demo uses an integrated silicon pressure sensor Freescale and MPXV7025DP. It is a differential pressure sensor that delivers an analog output voltage proportional to the applied pressure The key features of this pressure sensor are listed below:

- Pressure range -25 to 25 kPa (-3.6 to 3.6 psi).
- Output 0.2 to 4.7 V.
- 5.0 % Maximum error over 0° to 85°C.

- Ideally suited for both microprocessor and microcontroller systems.
- Temperature compensated over -40° to $+125^{\circ}\text{C}$.

The sensor is embedded in an AFE board. This contains a pair of pipes in its shell to allow a different pressure applied on each one of them and being capable of detect the direction of air flow. Both the sensor and the board are showed in Fig. 7. In order to work pressure sensor properly, it has to be connected as shown in Fig. 8.

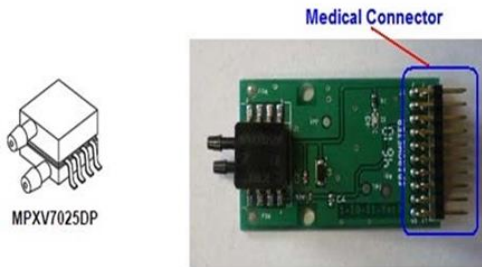

Fig. 7. Pressure sensor and AFE

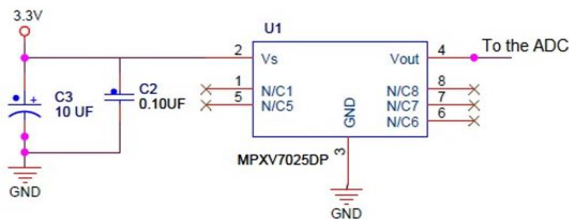

Fig. 8. Pressure sensor connections

B. Temperature Sensor

The working of Lm25 described as follows:

There are two transistors at center of the drawing. First one has ten times the emitter area of the other. This means it has current density one tenth of other, but same current is passing through both transistors. This causes a voltage across the resistor R1 that is proportional to absolute temperature, and it's linear across the range we care almost. The range is taken care of by a precise circuit that straightens the slightly curved graph of voltage versus temperature.

Amplifier at the top most ensures that voltage at the left transistor (Q1) is proportional to absolute temperature (PTAT) by comparing the two transistors output.

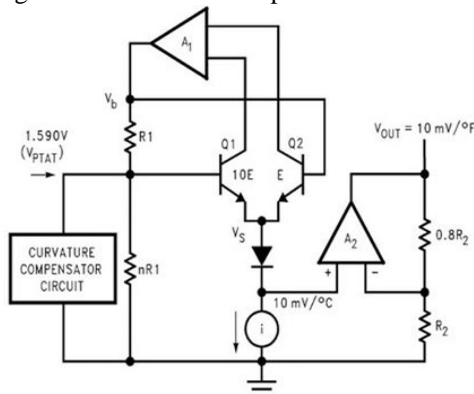

Fig. 9. Schematic figure of lm35

The amplifier at the right converts absolute temperature (measured in Kelvin) into Fahrenheit or Celsius, based on the part (LM34 or LM35). The little circle with the "i" in it is a constant current source.

The two resistors are calibrated in the factory to produce a highly accurate temperature sensor. In an IC many transistors will be there two in the middle, some in each amplifier, constant current source, and rest in the curvature compensation circuit. The entire circuit is fitted in the tiny package with three leads.

C. Software Program Burner

Burner/microcontroller programmer a hardware device accompanied with software which is used to transfer the machine language code from the PC to the microcontroller/EEPROM. The compiler converts the code written in assembly languages like, C, java etc to machine understandable language code (which is identified by the machines/microcontrollers) and it is stored in a hex file. The programmer acts as an interface between the PC and the target controller. The API/software present in programmer read data from the hex file which in PC and feeds it into the controller's memory. The controller in which the program is to burn is placed on the programmer using a ZIP socket.

The data is transfer from the PC to the hardware using serial, parallel or USB port.

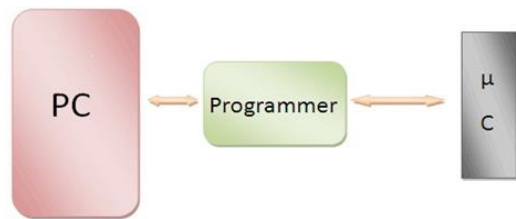

Fig. 10. Block diagram

D. PROGISP Software



Fig. 11. Software view

PROGISP is a way for, in system programming of micro controllers in controlled way. Its development credit goes to Chi Feng Technology Co., Ltd, which engages in the design of embedded systems products, sharing and free software developing. PROGISP ver1.68 supports for nearly 110 CPUs with on board by default fuse bits selection for every controller. It has friendly user interface with required graphics.

E. AVR Studio IDE

The Integrated Development Environment (IDE) is a software application that provides comprehensive facilities to programmers for software development. In IDE normally consists of a source code editor, build automation tools and debugger. Latest modern IDEs integrate with Intelligence coding features.

Some IDEs contain an interpreter, compiler, or even both, such as Net Beans and Eclipse; others don't have, such as Sharp Develop and Lazarus. The boundary between an IDE and other broader software development environment is not well defined. In some cases a version control system and other various tools are integrated together to simplify the construction of a GUI. Modern IDEs will have a class and object browsers, a class hierarchy diagram, are used in object-oriented software development. This section gives a brief description of the main features of AVR Studio. This enables execution of AVR programs on an AVR In-Circuit Emulator or the built-in AVR Instruction Set Simulator. For executing a program using AVR Studio, it must first be compiled with IAR Systems' C Compiler or assembled with Atmel's AVR Assembler in order to generate an object file which can be read by AVR studio.

IV. RESULTS

The health parameters is displayed in the web page as shown below,



Fig. 12. Health parameters on the webpage

As if we can see the result in the both value format as well as in the graph format as shown below,

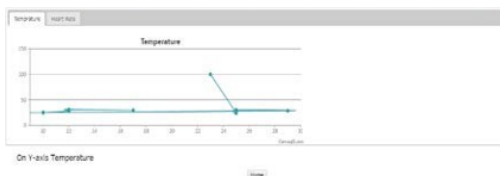

Fig. 13. Graph format

A. Details of the Work Done

By taking the health parameters from the patient, i have send it to the web page through the gateway and displayed in the webpage.

B. Future Work

By using Raspberry pi need to send the data through the network to all the system by using Internet and send to the webpage using a Django web Framework.

V. CONCLUSION

With the wide use of internet this work is designed to implement the internet technology to establish a system which will communicate through internet for better health. IOT is expected to rule the world in various fields but more benefit would be in the field of healthcare. So present work is done to design an IOT based smart healthcare system using a microcontroller ATMEGA8. In this work the MCP6004 based Pulse oximeter is designed for heart rate monitoring, LM35 temperature sensor is to measure temperature of the patient, the microcontroller will pick up the data and send it through MSG91. During extreme conditions to alert the doctor a message is sent to the doctor's phone through GSM modem and at the same time to alert the caretaker buzzer will turn ON. The doctors can view the data by logging into the html webpage using unique IP and page will refresh automatically so continuous data reception is achieved. By this way continuous patient monitoring system is designed. In order to make the design system more advanced future scope of the project is essential. In order to enhance the system connecting more sensors to internet for measuring various other health parameters, Patient will be more benefited by this monitoring i.e. for quick and easy access connecting all the objects to internet. Establishing a Wi-Fi mesh type network is to increase in the communication range.

REFERENCES

- [1] Vandana Milind Rohokale, Neeli Rashmi Prasad, Ramjee Prasad "A Cooperative Internet of Things (IoT) for Rural Healthcare Monitoring and Control" 2011 Center for TeleInfrastruktur, Aalborg University, Denmark, P.P 978-1-4577-0787-2/11.
- [2] Charalampos Doukas, Ilias Maglogiannis "Bringing IoT and Cloud Computing towards Pervasive Healthcare" 2012 Sixth International Conference on Innovative Mobile and Internet Services in Ubiquitous Computing, P.P 978-0-76954684-1/12.
- [3] Junaid Mohammed, Abhinav Thakral, Adrian Filip Ocneanu, Colin Jones, Chung-Horng Lung, Andy Adler "Internet of Things: Remote Patient Monitoring Using Web Services and Cloud Computing" 2014 IEEE International Conference on Internet of Things (iThings 2014), Green Computing and Communications (GreenCom2014), and CyberPhysical-Social Computing (CPSCoM 2014).
- [4] Tae-Yoon Kim, Sungkwan Youm, Jai-Jin Jung, Eui-Jik Kim "Multi-hop WBAN Construction for Healthcare IoT" 2015 International Conference on Platform Technology and Service, P.P 978-1-47991888-1/15.
- [5] <http://help.msg91.com/article/169-how-does-send-otp-work>.
- [6] <https://sendotp.msg91.com/doc>
- [7] <https://www.quora.com/How-does-LM35-work>.
- [8] https://en.wikipedia.org/wiki/Bedwetting_alarm
- [9] <https://www.uic.edu/apps/phpmyadmin/Documentation.html>