

A Study and Development of Conventional Steerable Bogie Frame on Train Engine

R. Mohammad Giyahudeen¹

¹Assistant Professor, Department of Mechanical Engineering, Maha Barathi Engineering College, Chinnasalem, India

Abstract— A bogie is a chassis or framework carrying wheels, attached to a vehicle, thus serving as a modular sub assembly of wheels and axles. Most bogies have rigid frames. There are many problems in sharp curves negotiation such as large lateral force, squeal noises and excessive wear of wheel flange and rail gauge corner in rigid frames. To overcome some of the mechanical problems of the rigid wheel set mounted in a rigid bogie frame, some modern designs incorporate a form of radial movement in the wheel set.

Index Terms— Bogie, conventional bogie, rigid bogie frame, Steering Mechanism.

I. INTRODUCTION

The bogie used in Indian Railways is conventional rigid bogie frame (i.e.) the axle of the bogie does not turn during a curve in the track. The frame of the ICF bogie is a fabricated structure made up of mild steel. Main sub-assemblies of bogie frame viz. side frames, transoms, headstocks, longitudinal forms the skeleton of the bogie frame. The sub-assemblies are fabricated from flanges, webs, channels and Ribs by welding process. Various types of brackets are welded to the frame for the purpose of primary and secondary suspension arrangement, alternator suspension arrangement and brake rigging arrangement. This document is IJRESM template. Any queries on paper preparation & guidelines, please contact us via e-mail.



Fig. 1. Train Engine



Fig. 2. Assembly of Bogie Frame

Important parts of the Bogie:

1. Bogie Frame
2. Axle
3. Wheel
4. Bull Gears
5. Suspension Tube
6. Axle Boxes
7. Traction Motor
8. Air Piping
9. Brake Rigging Items (Levers)

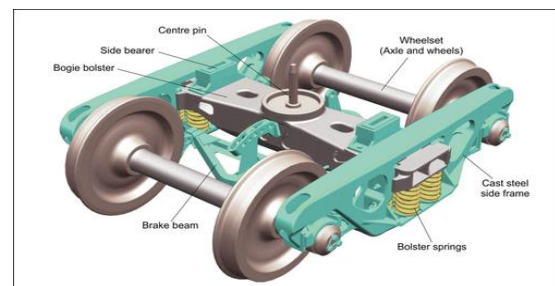

Fig. 3. Conventional bogie frame

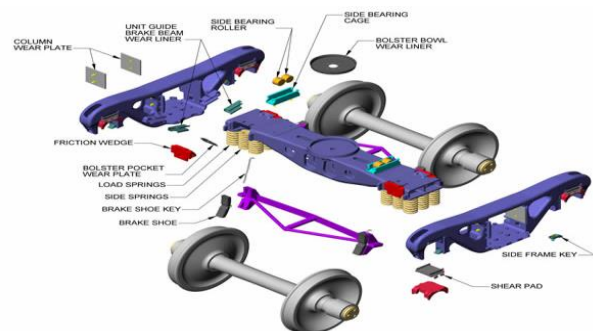

Fig. 4. Parts conventional bogie

Various brackets viz. brake hanger brackets, brake lever hanger brackets, brake cylinder fixing brackets, anchor link brackets, bolster spring suspension brackets, alternator suspension brackets, belt tensioning brackets, axle box guides, suspension straps are welded on the bogie frames. It involves 40 meters (app.) of welding in a single conventional bogie frame. Based on load carrying capacity per axle, the conventional bogie frames are grouped in to two types. They are 13 ton bogie frame and 16 ton bogie frame. 13 ton bogie frames are being used in the bogies of all non-AC mainline coaches and 16 ton bogie frames are being used in bogies of all

AC coaches, power cars and diesel multiple unit trailer coaches.

II. CONVENTIONAL BOGIE

Railway wheels sit on the rails without guidance except for the shape of the tyre in relation to the rail head. Contrary to popular belief, the flanges should not touch the rails. Flanges are only a last resort to prevent the wheels becoming derailed - they're a safety feature. The rails are also set at an inward angle.

The wheel profile should be determined by the rail angle. Of course, it varies from place to place but it is rarely a simple angle. It's usually a carefully calculated compound form. With respect to the rail angle, in the UK for example, it is set at 1 in 20 (1/20 or 0.05). In the US and France it's usually at 1/40. Light rail systems operating over roadways will have special profiles. The easiest way to prepare your document is to use this document as a template and simply type your text into it.

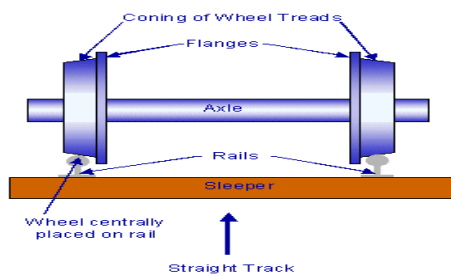

Fig. 5. Wheel on a straight track

On curved track, the outer wheel has a greater distance to travel than the inner wheel. To compensate for this, the wheel set moves sideways in relation to the track so that the larger radius on the inner edge of the wheel is used and smaller radius on the outer edge of the wheel.

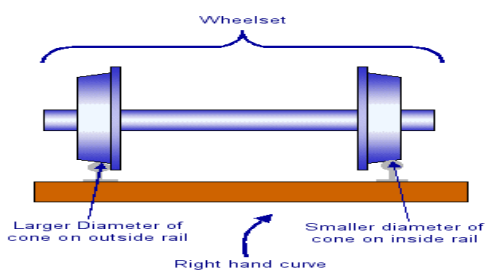

Fig. 6. Wheel on a curved track

The inner wheel uses the outer edge of its tyre to reduce the travelled distance during the passage round the curve. The flange of the outer wheel will only touch the movement of the train round the curved rail is not in exact symmetry with the geometry of the track. This can occur due to incorrect speed or poor mechanical condition of the track or train. It often causes a squealing noise. It naturally causes wear. Many operators use flange or rail greasing to ease the passage of wheels on curves. Devices can be mounted on the track or the train. It is important to ensure that the amount of lubricant applied is exactly right.

Too much will cause the tyre to become contaminated and will lead to skidding and flatted wheels. There will always be some slippage between the wheel and rail on curves but this will be minimized if the track and wheel are both constructed and maintained to the correct standards.

A pair of train wheels is rigidly fixed to an axle to form a wheel set. Normally, two wheel sets are mounted in a bogie, or truck. The bogie frame is turned into the curve by the leading wheel set as it is guided by the rails. However, there is a degree of slip and a lot of force required to allow the change of direction. The bogie is, after all, carrying about half the weight of the vehicle it supports. It is also guiding the vehicle, sometimes at high speed, into a curve against its natural tendency to travel in a straight line.

A conventional bogie tends to take an understeer attitude, or to turn outwards with respect to the tangent of the curve, and as a result, the front axle has an angle of attack to the curve, which gives rise to a lateral creep force pressing the outer wheel to the outer rail. On the other hand, the rear axle stays near the track centre, and consequently, the differential wheel diameter is insufficient, and there occurs a longitudinal creep force (tangential force) between the rear wheels and the rails. These forces act as anti-steering moments on the bogie, and cause high lateral force of the front wheel set toward the outer rail.

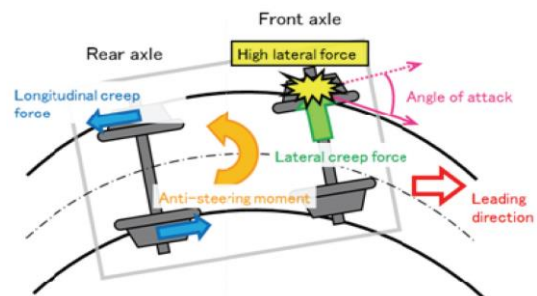

Fig.7. Force acting on a conventional bogie

The problems with railway vehicles at sharp curves are large lateral force and high derailment coefficient, an indicator of running safety defined as the lateral force of a wheel on the rail divided by the vertical load. In addition, because the wheels turn at sharp curves with their flanges contacting the gauge corner of the outer rail, there are other problems arising from the wheel/rail contact such as high-frequency noises and the wear of the wheel flanges and the gauge corner of the rail.

In view of the large lateral force and high derailment coefficient, derailment is prevented physically by providing anti-derailment angles or rails along the inner rail.

Since the above large lateral force, high-frequency noises, and the wear of the flanges and the rail gauge corner result from wheels contacting the rail, they have been taken care of by providing oiling facilities to the tracks or wheels for lubrication control. Oiling, however, often leads to wheel spinning during power running or slipping during braking, and thus is not adequate for curves. Spray of a special friction control agent has been developed and introduced recently to enable both

smooth power running and braking at curves, but further improvement is required.

III. STEERABLE BOGIE CONCEPT

To overcome some of the mechanical problems of the rigid wheel set mounted in a rigid bogie frame, some modern designs incorporate a form of radial movement in the wheel set.

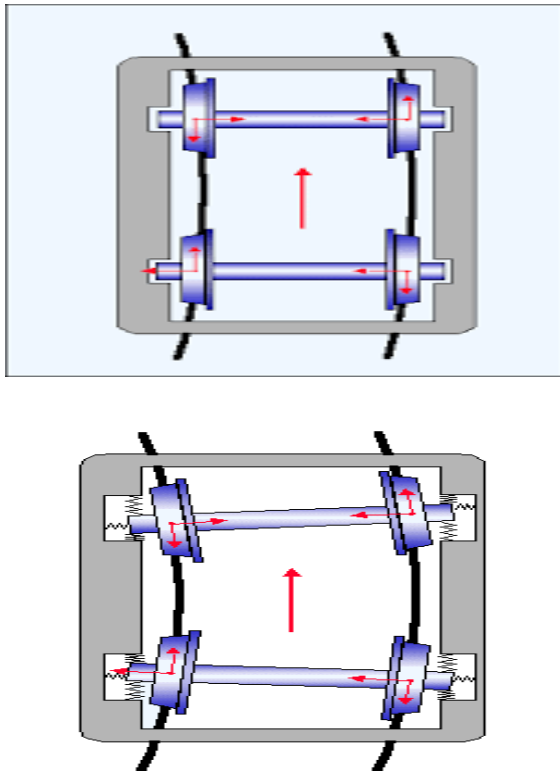

Fig. 8. Steerable Bogie on track

As in the automobiles the axles of the locomotives cannot be steered. Since the axle is fitted to the frame by the suspension. So it is difficult to steer the axle. The axle of the bogie has a bearings axle cup fitted at its either side. Axle box housing has a suspension spring which is connected to the frame of the bogie.

The above shown concept of steerable bogie is a theoretical method of steering the axle. But to make this apply in conventional bogie certain modifications are required in the frame. The frame is divided into two and is connected to make a flexible hinge. Separate linkages are required to make the frame flexible.

The design of steerable bogie has been in the development for the past 50 years. But the use of steerable bogie is first made in Japan for a Tokyo metro line SC 101 series. This design involves the use of linkages for each bogie separately. So the angle of attack will be different for bogies in the coach. In order to make the equal angle of attack in all bogies of the coach cross linking of the linkages are required. This paper will add some advantages to the newly developed steerable wheels.

IV. NEWLY DEVELOPED STEERABLE BOGIE

The mechanism by which the developed steering bogie negotiates a curved track is illustrated in the figure. The rear axle of the developed bogie is steered, and consequently, the angle of attack of the rear axle increases, which leads to a lateral creep force toward the outer rail, and accordingly the axle shifts toward it. As a result, the insufficiency in the differential diameter between the rear wheels is alleviated, and the longitudinal creep force of the axle in the anti-steering direction decreases. In addition, the shifting of the rear axle toward the outer rail improves the attitude of the bogie from under-steer to a radial turn. As a result, the angle of attack of the non-steered front axle decreases, and so does the lateral creep force. The decrease in the longitudinal creep force of the rear axle and that in the lateral creep force of the front axle reduce the anti-steering moment of the bogie, as well as the lateral force of the front wheel on the outer rail.

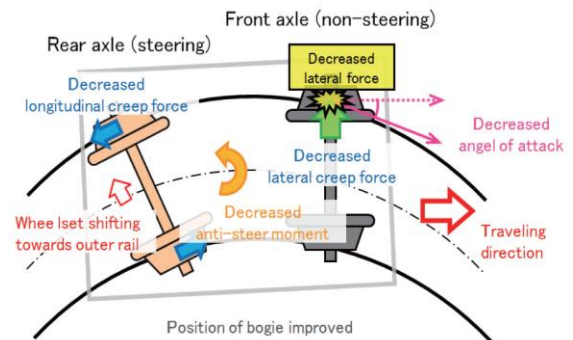

Fig. 9. Forces acting on a steerable bogie

The configuration of a Series 1000 vehicle equipped with the new bogies is given in figure 7. While only the rear axle is to be steered, since railway vehicles run in both directions, the Nos. 1 and 4 axles on the body-end sides are not steered. The intention in the design is to steer the Nos. 2 and 3 axles to improve the curve negotiation performance of the leading axle of each vehicle in either direction of travel.

In the case of the rear bogie of a vehicle, its front axle, or the No. 3 axle, is steered. Since the leading axle of the bogie is steered, its angle of attack decreases, so does the lateral creep force, and consequently, the lateral force on the outer rail decreases.

The axle boxes of the non-steering (Nos. 1 and 4) axles on the body-end sides are connected to the bogie frame using conventional mono-link suspensions. To realize high reliability, the traction motor, the gear box, and the tread brake systems, which have been time-proven with conventional bogies, is used for the bogie.

With the steering (No. 2 or 3) axle on the body-centre side, the brake systems pose a problem: since the wheels change their positions with respect to the bogie frame, common thread brake systems are not applicable. To solve the problem, disc brake was applied to the steered axle to allow for its displacement with respect to the bogie frame.

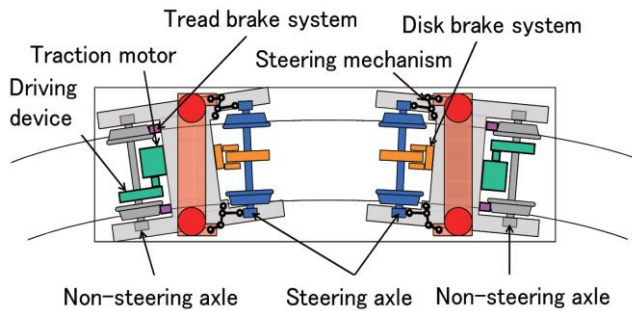

Fig. 10. Steering Mechanism in SC 102 Bogie

V. INNOVATION IN STEERABLE BOGIE

The steering mechanism of SC 102 has separate linkages to each of the bogie. Mostly the coaches of Indian Railways have two bogies. So in order to reduce and equalize the angle of attack on both the bogies they are connected by using the slotter mechanism.

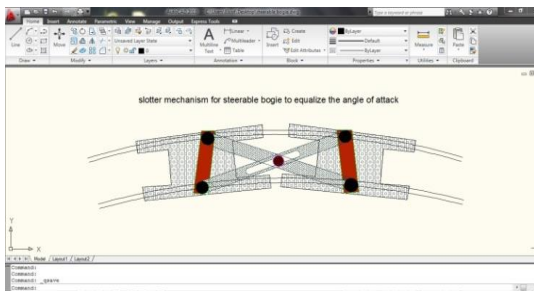

Fig. 11. Slotter mechanism for steerable bogie

So during the turning (curve) the rear axle of the first bogie and the front axle of the second bogie are steered. This self-steering with equalized angle of attack makes additional advantage to the steerable bogie. The same principle is applied to the reverse direction of the train. Since the wheel set 2 the flexible frames of both the bogies (i.e.) the linkage mechanisms of wheel set 2 and wheel set 3 are connected through the slotted frames. The frames are cross linked with the wheel set 2 and 3 are steered. This innovation is illustrated in the AutoCAD drawing.

VI. CURRENT STATUS

The steerable bogie is used in Tokyo's Ginza line SC 102 train. Other than this the steering of bogie wheels is hydraulically controlled by South Africa train- DCD's Jika hydraulic self-steering bogie. The major benefit of DCD's new hydraulically actuated bogie steering mechanism is that wheel flange wear is about eight times less than before. This will mean three times more life for the average locomotive wheel. Bombardier FLEXX Tronic technology overcomes conventional bogie limitations such as passive steering and suspension elements. Mechatronics in the bogie, arguably a train's most crucial component, provide unique new functionalities like active radial steering (ARS) and bogie

stabilization active comfort improvement, tilting, intelligent condition monitoring.

VII. DRAWBACKS OF STEERABLE BOGIE

In spite of the advantages of the steerable bogie it has some drawbacks like difficult to change existing bogie of the trains. Maintenance becomes one of the issues of steerable bogie since it has the flexible linkages. Other than changing the frames of the bogie the suspension, location of driving unit must have to be changed. Additionally a disc brake must have to be mounted to slow down the train during taking curve. Because, the shoe brake cannot be used on the wheels of the axle which is steering.

VIII. CONCLUSION

The development of a steerable bogie offers more advantages when compared to the conventional bogie in the form of decreased wear of the wheel and the rails squeal noise, lateral force, creep force and the angle of attack. So, many countries are doing research in steerable bogie in order to increase the life of the wheels. Though it will take some years to completely change the rigid bogie into flexible bogie with the electronically controlled steering of the axle, the steerable bogie is the best alternative to rigid conventional bogie. From the analysis conducted in SC 102 metro train the lateral forces reduced by 32% when compared to the conventional rigid bogie. In addition to that the angle of attack and the load acting on the linkages between axle box and the bogie frame are reduced.

REFERENCES

- [1] wikipedia.org/wiki/Bogie
- [2] www.railway-technical.com/whlbog.shtml
- [3] Development of the new concept steering bogie yoshiyuki shimokawa masaaki mizuno 2013
- [4] www.railwaysafrica.com/vn/2013/11/01/a-milestone-in-bogie-design/
- [5] www.bombardier.com/en/transportation/products-services/bogies/innovation-technology.html