

# Solar Controlled Unmanned Seed Sowing Robot

P. Giftson Paul<sup>1</sup>, B. Jyothir Rishreek<sup>2</sup>, Y. Sharan Kumar<sup>3</sup>, M. R. Mahalakshmi<sup>4</sup>, L. Jiban Priya<sup>5</sup>

<sup>1,2,3</sup>Student, Department of Electronics and Communication Engineering, Sri Muthukumar Institute of Technology, Chennai, India

<sup>4,5</sup>Assistant Professor, Department of Electronics and Communication Engineering, Sri Muthukumar Institute of Technology, Chennai, India

**Abstract:** In our country most of the contemporary machines use the power by burning of fossil fuels to run IC engines or external combustion engines. This evidently has led to widespread air, water and noise pollution and most importantly has led to a realistic energy crisis in the near future. This proposed project is designed to develop an automatic system to minimize the working cost and also to reduce the time for digging and seed sowing operation by utilizing solar energy. In this system solar panel is used to capture solar energy and then it is converted into electrical energy which in turn is used to charge 12V battery, which then gives the necessary power to a shunt wound DC motor. This power is then transmitted to the DC motor to drive the wheels. IR sensors are used to maneuver robot in the field which reduces man power. Here 4 post sensors are used to define the territory and robot senses the track length and pitch for movement from line to line. Thus the proposed system implements automatic Seed sowing and digging process using robot which is cost and energy efficient.

**Keywords:** Solar energy, DC motor.

## 1. Introduction

India is the place known for villages. This being said the major occupation of majority of villages in India is agriculture. Our whole economy is based on agriculture. Agricultural field involves the effective production of food, feed, fiber, and other goods for humans and animals. Also agriculture includes operations like production of cut flowers, timber, fertilizers, animal hides, leather, and industrial chemicals. Heavy material handling is required in the farming operations. For example, in vegetable cropping, handling of heavy vegetables in organic farming, handling of heavy compost bags. Near about 70% people are dependent upon agriculture. Agriculture has been the backbone of the Indian economy and it will continue to remain so for a long time. It has to support almost 17 per cent of world population from 2.3 per cent of world geographical area and 4.2 per cent of world's water resources. The economic reforms, initiated in the country during the early 1990s, have put the economy on a higher growth trajectory

In the current generation most of the countries do not have sufficient skilled man power in the agriculture sector and it affects the growth of developing countries. The basic operation of sowing machine is to sow the seed in row at the required depth and maintain the distance between two seeds. Solar panel is used to capture solar energy and then it is converted into

electrical energy. This energy is used to charge 12V battery which is utilized by DC motors. We enter the distance between two seeds through keypad. LCD is used to display the battery level. By using this innovative project of seed sowing machine we can save more time required for sowing process and it also reduces laborer cost. This machine controls the seed depth and proper utilization of seeds to reduce the wastage of seeds.

## 2. Objective

The main aim of our project is to offer medical services to people in rural areas across the country at lower costs. People in rural areas do not have a facility to get treated by a medical expert. So, this project provides them an opportunity to get treated indirectly through the virtual environment called as the care equipment. This has the medicines that are recommended by the medical experts. This project also deals with the signal conditioning and data acquisition of four vital signs of human body i.e., heart rate, blood pressure, body temperature and diabetes. In case of any issues in the patient's health, it uses Internet to inform our loved ones. For an emergency case, the ambulance also arrives to the patient's locality with the help of GPS since we can track the latitude and longitude location.

## 3. Literature survey

Swetha and Shreeharsha G.H designed a machine solar panel captures the solar energy and then is converted into electrical energy which in turn is used to charge 12V battery, which then gives the necessary power to a shunt wound motor to drive the wheels fulfilling tasks like digging, seed sowing, water pouring and fertilizing. Though it is described as automated machine, manpower is needed for a certain operation.

Anuja Mohalkar and Priti Mohite proposed this machine is to automate the process of digging and seed sowing at proper distance and depth. This works with the help of solar energy. There is no proper germination of seeds and also wastage of seeds occur. Here the remote control feature is not used and the water dripping unit is also not included. Manjesh M. N designed the This automatically positions the seeds in sand and covers them without human involvement & is a sunlight based fueled machine. There is no control over the depth of seed placement. And sowing during the Autumn

season can bring damage by overwinter wet and cold.

John Chembukkavu, Aslam Basheer, Basil N Basheer has come with this machine solar panel is used to capture solar energy which is then converted into electrical energy to charge 12V battery, which then gives the necessary power to a shunt wound DC motor. This power is then transmitted to the DC motor to drive the wheels. Seed sowing and digging robot will move on different ground contours and performs digging, sow the seed and water the ground after closing.

Kalash Singhal, Gaurav Prajapati This machine uses solar energy as an eco-friendly energy resource. Seed Hopper and Water Tank are used for seed sowing and irrigation operations respectively. Here there is no uniformity as there are no seed spacing sensors and it also does not check the moisture level of soil.

#### 4. Methodology

In this machine a solar panel is used to capture solar energy and then it is converted into electrical energy which in turn is used to charge 12V battery, which then gives the necessary power to a shunt wound DC motor. This power is then transmitted to the rear wheel through chain drives. Consequently, in this project an attempt is made to make the electric and mechanical systems share their powers in an efficient way. The basic objective of sowing operation is to put the seed and fertilizer in rows at desired depth and seed to seed spacing, cover the seeds with soil and provide proper compaction over the seed. The recommended row to row spacing, seed rate, seed to seed spacing and depth of seed placement can vary from crop to crop and for different agro-climatic conditions to achieve optimum yields. Typical application of seed sowing of Cereals including ground nut, all types of dal, oil seed crop's etc. A solar panel is a device that collects and converts solar energy into electricity or heat or mechanical work. Solar energy is first used to charge a storage battery. An electric battery is a device consisting of one or more electrochemical cells that convert stored chemical energy into electrical energy. The solar energy stored in the battery is utilized to operate DC motor. A DC motor is a device that converts direct current (electrical energy) into mechanical energy. By using the bevel gear and Chain drive with sprockets power is transferred to the wheels for their movement. AT89S52 Microcontroller is used to automatically control the machine.

#### 5. Block diagram

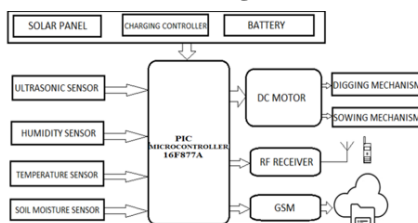

Fig. 1. Block diagram

#### A. Ultrasonic sensor

The Ultrasonic sensor is interfaced with the controller in order to monitor and detect any kind of obstacles that obstruct the robot vehicle. This work by emitting sound waves at a frequency too high for human to hear. They then wait for the sound to be reflected back, calculating distance based on the time required.



#### B. Soil moisture sensor: (ADC121CO2)

The Soil Moisture Sensor uses capacitance to measure dielectric permittivity of the surrounding medium. In soil, dielectric permittivity is a function of the water content. The sensor creates a voltage proportional to the dielectric permittivity, and therefore the water content of the soil.



#### C. Temperature & humidity sensor

A temperature sensor is a device, typically, a thermocouple or RTD, that provides for temperature measurement through an electrical signal. A thermocouple (T/C) is made from two dissimilar metals that generate electrical voltage in direct proportion to changes in temperature.

Humidity Sensors are very important devices that help in measuring the environmental humidity. Technically, the device used to measure the humidity of the atmosphere is called Hygrometer.



#### D. Solar panel

Solar Panel provides renewable and eco-friendly source of energy. It is made up from Photovoltaic(PV) cells. It absorbs sunlight and convert this solar energy into electrical energy.

#### Specifications:

- Rated Power: 40W
- Dimension: 470mm x 350mm x 25mm



**E. Lead Acid Battery**

It consists electrochemical cells which convert stored chemical energy into electrical energy. Each cell contains a positive terminal and a negative terminal. Electrolyte is responsible for ions mobilization between electrodes and terminals. These ions mobilization allow current to stream out of the battery to perform work.

*Specifications:*

Rated Voltage: 24V

**F. DC motor**

According to Ampere’s Law, a wire which carries an electric current produces a magnetic field around it. Following this law, DC Motor creates the mechanical work from electrical energy.

*Specifications*

- Rated Voltage: 24V
- Speed: 1800rpm



**G. The Internet of Things**

(IoT) is a system of interrelated computing devices, mechanical and digital machines, objects, animals or people that are provided with unique identifiers (UIDs) and the ability to transfer data over a network without requiring human-to-human or human-to-computer interaction. The definition of the Internet of things has evolved due to the convergence of multiple technologies, real-time analytics, machine learning, commodity sensors, and embedded systems.



**H. The Global System for Mobile Communications**

A GSM is a standard developed by the European Telecommunications Standards Institute (ETSI) to describe the

protocols for second-generation (2G) digital cellular networks used by mobile devices such as mobile phones and tablets.



**6. Advantages**

Working speed of the machine depends upon the DC motor and energy stored in the battery. Prototype Machine can dig the soil in three rows up to 5 inch by rotating the digging tool by the help of DC motor. Digging speed depends on the moisture content in the soil and tool tip. At the same instant from the seed dropper seed is placed in all the three rows at a distance of 4 inch.

**7. Applications**

Safer and more efficient as they provide a safe route for farmers. Digging operation, sowing mechanism and water dripping are done sequentially. It is extremely appropriate for huge fields.

**8. Output**

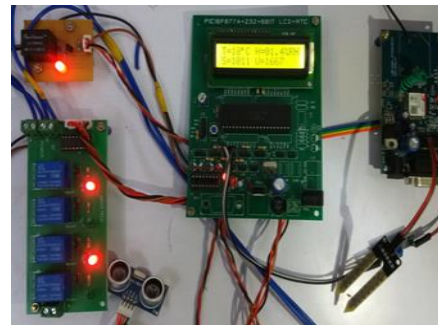

Fig. 2. Output

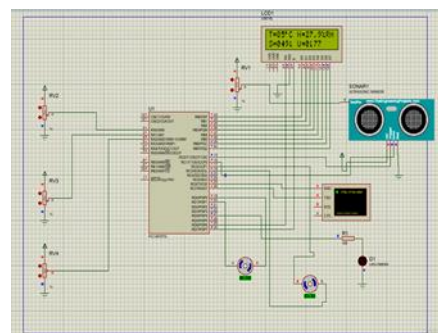

Fig. 3. Simulation output

**9. Future scope**

Introduction of drill in place of cutter can be used as soil erosion equipment. Machine can be operated automatically

with the help of navigation sensors. Seed Spacing sensors can be used for accurate spacing.

### 10. Conclusion

Innovative seed sowing equipment's has exceptional influence in agriculture. By using this innovative project of seed sowing gear, we can spare more time required for sowing process and additionally it reduces lot of labor cost. It is very helpful for small scale farmers. After comparing the distinctive method of seed sowing and restrictions of the existing machine, it is concluded that this solar powered seed sowing machine can Maintain row dispersing and controls seed rate. Control the seed depth and legitimate utilization of seeds can be done with less misfortune. Perform the different simultaneous operations and hence saves work requirement so as labor cost, labor time and also save parts of energy. Hence it is easily affordable by farmers. So we feel that this project serves something good to this world and we would like to present it before this prosperous world. It can be concluded that:

1) Sowing rate can be controlled

- 2) Seed spacing can be achieved
- 3) Less manual power is required
- 4) No pollution is caused
- 5) Economical
- 6) Variety of seeds can be sowed.

### References

- [1] Swetha S. and Shreeharsha G.H, "Solar Operated Seed Sowing Machine", International Journal of Advanced Agriculture Sciences and Technology 2015, Volume 4, Issue 1, pp. 67-71, 2015.
- [2] Ahuja Jayesh, Bhoite Aakash, Patil Mayur, Tinwala Ensiya, Kumar Sham., "An Innovative Model for Multipurpose Agricultural Use", International Journal of Advance Engineering and Research Development, Volume 4, Issue 3, March 2017.
- [3] Sahay (1990), Principals of Agricultural Engineering (2005), Volume 1, Text book published by Jain brothers, New Delhi, India.
- [4] N. Iqbal, N. Akbar, M. Ali, M. Sattar, L. Ali, "Effect of seed rate and Row spacing on yield and yield components of Wheat," Journal of Agricultural Research, 48(2).
- [5] Mahesh R. Pundkar, "A seed sowing machine: A review", International journal of engineering and social science.
- [6] P. P. Shelke, "Frontline demonstration on bullock-drawn planter enhances yield of soya bean crop," International journal of farm science.