

# Modeling and Analysis of Centrifugal Blower

Sk. Abdul Samad<sup>1</sup>, Sk. Shahul<sup>2</sup>

<sup>1</sup>M.Tech. Student, Department of Mechanical Engineering, Brahmaiah College of Engineering, Nellore, India

<sup>2</sup>Assistant Professor, Department of Mechanical Engineering, Brahmaiah College of Engineering, Nellore, India

**Abstract:** Centrifugal blowers are utilized extensively for on-board naval applications that have high noise levels. The noise generated with a rotating component is principally because of random loading pressure around the blades and periodic iteration of incoming air using the blades from the rotor. The contemporary blades in naval applications comprise Aluminum or Steel and generate noise that triggers disturbance to folks working close to the blower. The current work is aimed at observing the option of E-Glass instead of metal for much better vibration control. E-Glass, recognized for their superior damping characteristics tend to be more promising in vibration reduction when compared with metals. The modeling from the blower ended by solid works. It's suggested to create blower with Epoxy glass, evaluate its strength and deformation using FEM technique. To be able to evaluate the potency of E-Glass and metal blower using FEA packaged (ANSYS). Modal analysis is conducted on Aluminum and E-Glass blower to discover first five natural frequencies.

**Keywords:** Blower design, E-Glass blower, Noise levels, Vibration control.

## 1. Introduction

Blowers are among the mechanisms used regularly in submarines. They're set up in ventilation and method in just about all submarine compartments. systems include supply and exhaust fans, serve for ventilation of accommodation along with other than accommodation areas with atmospheric air with synchronized ventilation of storage batteries as well as for air cooling and purification from dangerous and smelling impurities. Method is presented by local, compartment group and single duct systems.

Scalping strategies are utilized to provide comfortable conditions when it comes to air humidity and temperature for that crew in accommodation areas, air purification in galleys, provision rooms, and sanitary areas and for air mixing in compartments. All blowers are meant for submarine installation is different from industrial ones not just for his or her reliability and strength under dynamic impacts but in addition for low noise and vibration levels [1]. As blower represents most of submarine mechanisms, they ought to naturally satisfy the following compulsory needs for those mechanisms: Minimum weight-dimensional parameters reliable operation at submarine motions vibration and impact resistance, ease of mountings and simple use of lube points and keeping and services information existence at transportation and alterations in climate. Centrifugal blowers are mechanical devices made to move air along with other gases.

These blowers are capable to raise the air stream speed and velocity using the rotating impellers. Such fans are constant volume devices that perform at regular fan speed. A centrifugal blower has the ability to pump a stable volume stream of air rather of pumping constant mass, meaning system air velocity is bound regardless of the inconsistency from the fan mass flow rate. Centrifugal blowers use impeller kinetic energy or even the rotating blade in growing the environment or gas stream pressure which moves them as opposed to the resistance from dampers, ducts along with other similar components. Centrifugal blowers radically accelerate air, which changes the path of the air flow. These blowers are effective, quiet, dependable, and qualified to operate over a comprehensive number of conditions. Two of the most common kinds of Centrifugal Blowers are: 1. Pressure Blowers and a pair of. Volume Blowers. Centrifugal blower operating principle: The centrifugal blower operating principle is comparable to centrifugal fan, however the pneumatic compaction process usually passes several job impellers or several grades Keep on underneath the at odds using the community or even the leadership action of pressure. The environment blower includes a high-speed trochanter rotated, the blade in the trochanter drives our prime-speed sports of air, the centrifugal pressure helps make the ventilation in to the air blower and export across the involutes within the chassis from the involutes shape, and our prime-speed air current has certain wind pressure. It's supplemented the new air is joined through the center from the chassis. Centrifugal blowers typically operate against pressures of .35 to .70 kg/cm<sup>2</sup>, but could achieve much greater pressures. Also accustomed to produce negative pressures for industrial vacuum systems. Major types are centrifugal blower and positive-displacement blower. The impeller is usually gear-driven and rotates as quickly as 15,000 revolutions per minute. Efficiency drops with multi-staging staging because of the path obtained from stage to stage. One characteristic is the fact that air flow has a tendency to drop drastically as system pressure increases.

Positive Positive-displacement displacement blowers have rotors, which "trap" air and push it through housing. Positive-displacement blowers give a constant amount of air whether or not the system pressure varies. They're especially appropriate for applications vulnerable to clogging. They turn much slower than centrifugal blowers (e.g. 3,600 revolutions per minute), and therefore are frequently belt-driven to facilitate speed changes. A centrifugal blower has lots of fan blades which are mounted around a hub, which activates a driveshaft which goes

directly with the housing from the blower. The gas will penetrate in the fan wheel side, then will turn 90 levels after which will accelerate.

The impeller is switched either through the direct drive by an electric motor or implying pulleys & belts. Thus a centrifugal pressure is produced. It offers the required energy to maneuver the environment Orgasoline within the scroll at inlet & radically out with the outlet. The Contemporary blades in Centrifugal Blower utilized in naval applications comprise Aluminum or Steel. The goal of present jobs is to create an Impeller of the Centrifugal blower with four materials that are: Aluminum Alloy 1060, Graphite, Titanium, and E-glass/Epoxy. Blower power calculation: Blowers could be categorized as either (1) positive displacement blowers, which offer a continuing amount of air at an array of discharge pressures, or (2) centrifugal blowers, which offer an array of flow rates more than a narrow selection of discharge pressure (USEPA, 2010). The ability use of blower could be calculated using equation (1), which comes from adiabatic compression equation.

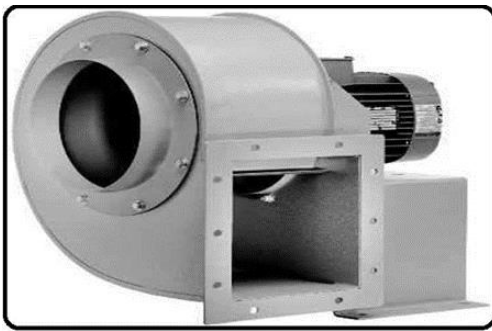

Fig. 1. Proposed model

## 2. Methodology

Probably the most effective features within the SolidWorks application is the fact that any change you are making to some part is reflected in almost any connected sketches or assemblies. The SolidWorks application includes a number of interface tools and abilities that will help you create and edit models efficiently. These power tools and abilities range from the following: Home windows functions SolidWorks document home windows and performance selection and feedback [4]. ANSYS Mechanical software provides a comprehensive product solution for structural straight line/nonlinear and dynamics analysis. SolidWorks utilizes a 3D design approach. While you design a component, in the initial sketch towards the final model, you develop a 3D entity. Out of this 3D entity, you may create 2D sketches, or mate different components to produce 3D assemblies. You may also create 2D sketches of 3D assemblies. The merchandise provides a complete group of elements behavior, material models and equation solvers for an array of engineering problems. Additionally, ANSYS Mechanical offers thermal analysis and coupled-physics abilities involving acoustic, piezoelectric, thermal-structural and thermal-electric analysis. ANSYS Structural software

addresses the initial concerns of pure structural simulations without resorting to extra tools. The merchandise offers all the strength of nonlinear structural abilities - in addition to all straight line abilities -to be able to provide the greatest-quality, most dependable structural simulation results available. ANSYS Structural easily simulates the largest and many intricate structures. ANSYS Professional software provides an initial step into advanced straight line dynamics and nonlinear abilities. That contains the strength of leading simulation technology within an easy-to-use package, ANSYS Professional tools provide users rich in-level simulation abilities without resorting to high-level expertise. ANSYS Design Space software is a straightforward-to-use simulation software program that gives tools to conceptualize design and validate tips on the desktop. A subset from the ANSYS Professional product, ANSYS design space enables users to simply perform real-world, static structural and thermal, dynamic, weight optimization, vibration mode, and safety factor simulations on designs.

without resorting to advanced analysis understanding [5]. The finite element method (FEM) (its request frequently referred to as finite element analysis (FEA)) is really a statistical way of finding approximate solutions of partial differential equations (PDE) in addition to of integral equations. The answer approach relies either on eliminating the differential equation completely (steady condition problems), or rendering the PDE into an approximating system of ordinary differential equations, that are then numerically integrated using standard techniques for example Euler's method, Runge-Kutta, etc. The Finite Element Technique is great for solving partial differential equations over complicated domains (like cars and oil pipelines), once the domain changes (as throughout a solid condition reaction having a moving boundary), once the preferred precision varies within the entire domain, or once the solution lacks level of smoothness. In solving partial differential equations, the main challenge would be to create a formula that approximates the equation to become studied, but is numerically stable, and therefore errors within the

input and intermediate calculations don't accumulate and make the resulting output to become meaningless [6]. There are lots of ways of using this method, with pros and cons.

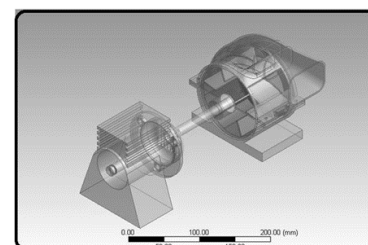

Fig. 2. Centrifugal blower

## 3. Conclusion

During Flow simulation at impeller output velocity is decreased when compared with inlet velocity, while output

pressure is elevated when compared with inlet pressure. Modeling and simulation of centrifugal blower fan has been doing using Solid Works software. After observing the static and dynamic analysis values we are able to conclude that e-epoxy has got the better stress bearing capacity in contrast to other materials except titanium deformation values by showing its better strength values towards the applied loads. By utilizing cost analysis methods, the fabric price of each metal is noted proven in graphs so we can watch that price of e-epoxy is a little more than aluminum which is reduced in lengthy run of producing. E-glass/Epoxy materials are non-metallic component. For manufacturing the centrifugal blower impeller, we are able to proceed with Epoxy/E-glass material since it has high stress bearing capacity and reasonable manufacturing.

### References

- [1] Raymond A. Loew, Joel T. Lauer, Joseph McAllister and Daniel L. Sutliff, "Advanced noise control Fan", Twenty-Fifth Aerodynamic Measurement Technology and Ground Testing.
- [2] Jeon Wan-Ho and Lee Duck-Joo, "A numerical study on the flow and sound fields of centrifugal impeller located near a wedge", Journal of sound and vibration, Volume 266, Number 4, pp. 785-804.
- [3] Jianfeng MA, Datong QI and Yijun MAO, "Noise reduction for centrifugal fan with non-isometric forward swept blade impeller", Energy Power Engineers, Volume 2, Number 4, pp. 433– 437.
- [4] Čudina, M. (2001). Noise generation in vane axial fans due to rotating stall and surge. Proceedings of the Institution of Mechanical Engineers, Part C: Journal of Mechanical Engineering Science, 215(1), 57–64.
- [5] Rama Krishna Shinagam, Rama Krishna A and Ramji K, "Experimental study on reduction of motor-fan noise by modification of blade and shroud configuration", Proceedings of the institution of Mechanical Engineers, Part C, Journal of mechanical engineering science, vol. 224, no. 2, pp. 315-320.