

A Novel High Step-Up Converter based on Three-Winding Coupled Inductor for Fuel Cell Energy Source Applications

Sk. Maheena¹, A. Yadunanda Kumar²

¹PG Scholar, Dept. of Electrical and Electronics Engg., Brahmaiah College of Engineering, Nellore, India

²Assistant Professor, Dept. of Electrical & Electronics Engg., Brahmaiah College of Engineering, Nellore, India

Abstract: High-efficiency DC–DC converters with high-voltage gain have been researched due to increasing demands. They are required as an interface system between the low voltages. This project presents a high step-up converter for fuel cell energy source applications with three-winding coupled inductor. The proposed high step-up dc–dc converter is devised for boosting the voltage generated from fuel cell to be a 400-V dc-bus voltage. Through the three-winding coupled inductor and voltage doubler circuit, the proposed converter achieve high step-up voltage gain without large duty cycle. The passive lossless clamped technology not only recycles leakage energy to improve efficiency but also alleviates large voltage spike to limit the voltage stress. Furthermore, the switch voltage stress and the diode peak current are also minimized. The switching loss is reduced due to soft switching. The circuit is simulated using MATLAB Simu-link. The circuit is implemented using embedded controller. Both Simulation and Hardware results is verified.

Keywords: Fuel cells, ZCS, Step up converters, RDS

1. Introduction

Recently, the cost increase of fossil fuel and new regulations of CO₂ emissions have strongly increased the interests in renewable energy sources. Hence, renewable energy sources such as fuel cells, solar energy, and wind power have been widely valued and employed. Fuel cells have been considered as an excellent candidate to replace the conventional diesel/gasoline in vehicles and emergency power sources. Fuel cells can provide clean energy to users without CO₂ emissions. Due to stable operation with high-efficiency and sustainable/renewable fuel supply, fuel cell has been increasingly accepted as a competently alternative source for the future [1]. The excellent features such as small size and high conversion efficiency make them valuable and potential. Hence, the fuel cell is suitable as power supplies for energy source applications.

The generated voltage of the fuel cell stack is rather low. Hence, a high step-up converter is strongly required to lift the voltage for applications such as dc micro grid, inverter, or battery. Ideally, a conventional boost converter is able to achieve high step-up voltage gain with an extreme duty cycle [7]. In practice, the step-up voltage gain is limited by effects of the power switch, rectifier diode, and the resistances of the

inductors and capacitors. In addition, the extreme duty cycle may result in a serious reverse-recovery problem and conduction losses. A flyback converter is able to achieve high step-up voltage gain by adjusting the turn's ratio of the transformer winding. In order to protect the switch devices and constrain the voltage spike, a high-voltage-rated switch with high on-state resistance (RDS-ON) and a snubber circuit are usually adopted in the flyback converter, but the leakage energy still be consumed. In order to increase the conversion efficiency and voltage gain, many technologies such as zero-voltage switching (ZVS), zero-current switching (ZCS), coupled inductor, active clamp, etc [2]. have been investigated. Some high step-up voltage gain can be achieved by using switched-capacitor and voltage-lift techniques, although switches will suffer high current and conduction losses.

2. Block diagram

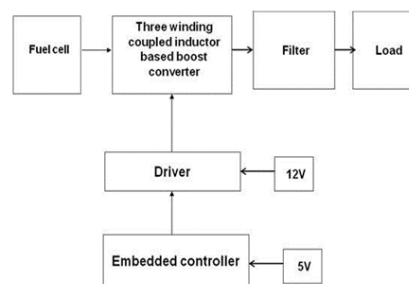

Fig. 1. Block diagram

It is the first stage of this project. So it is give the DC supply to Inverter. The DC source may be Battery or fuel cell or rectified from AC source Boost converter with coupled inductor. Boost converter is used to convert low voltage dc to high voltage dc [3].

PIC controller is used to generate triggering pulse for MOSFETs. It is used to control the outputs. Micro controller has more advantage compare then analog circuits and microprocessor such as fast response, low cost, small size and etc. [8]. It is also called as power amplifier because it is used to amplify the pulse output from micro controller. It is also called

as optocoupler IC. It provides isolation between microcontroller and power circuits.

RPS give 5V supply for micro controller and 12V supply for driver. It is converted from AC supply. AC supply is step down using step down transformer.

3. Circuit diagram and operating

A. Principle

The proposed converter employs a switched capacitor and a voltage-doubler circuit for high step-up conversion ratio. The switched capacitor supplies an extra step-up performance [4]. The voltage-doubler circuit lifts of the output voltage by increasing the turns ratio of coupled-inductor. The advantages of proposed converter are as follows:

1. Through adjusting the turns ratio of coupled inductor, the proposed converter achieves high step-up gain that renewable energy systems require;
2. Leakage energy is recycled to the output terminal, which improves the efficiency and alleviates large voltage spikes across the main switch;
3. Due to the passive lossless clamped performance, the voltage stress across main switch is substantially lower than the output voltage;
4. Low cost and high efficiency are achieved by adopting low-voltage-rated power switch with low RDS-ON;
5. By using three-winding coupled inductor, the proposed converter possesses more flexible adjustment of voltage conversion ratio and voltage stress on each diode [10].

The equivalent circuit of the proposed converter shown in Fig. 3 is composed of a coupled inductor T_r , a main power switch S , diodes D_1 , D_2 , D_3 , and D_4 , the switched capacitor C_b , and the output filter capacitors C_1 , C_2 , and C_3 [6]. L_m is the magnetizing inductor and L_{k1} , L_{k2} , and L_{k3} represent the leakage inductors. The turns ratio of coupled inductor n_2 is equal to N_2/N_1 , and n_3 is equal to N_3/N_1 , where N_1 , N_2 , and N_3 are the winding turns of coupled inductor. The steady-state waveforms of the proposed converter operating in CCM are depicted in Fig. 4. The each operating modes is shown in Fig. 5.

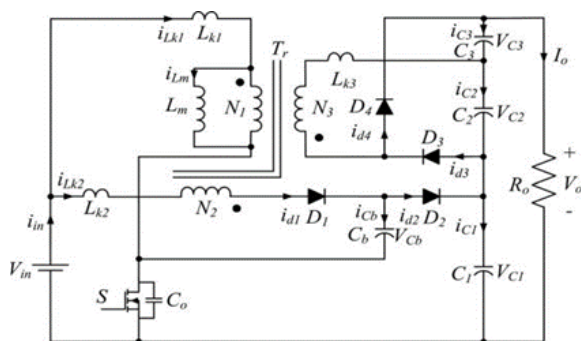

Fig. 2. Circuit diagram

B. Mode I [t0, t1]

During this interval, the switch S is turned ON at t_0 . The diodes D_1 , D_2 , and D_4 are reverse biased. The path of current flow is shown in Fig. 5. The primary leakage inductor current i_{Lk1} increases linearly, and the energy stored in magnetizing inductance still transfers to the load and output capacitor C_2 via diode D_3 .

C. Mode II [t1, t2]

During this interval, the switch S is still in the turn-on state. The diodes D_1 and D_4 are forward biased; diodes D_2 and D_3 are reverse biased. The path of current flow is shown in Fig. 5(b). The dc source V_{in} still charges into the magnetizing inductor L_m and leakage inductor L_{k1} , and the currents through these inductors rise linearly. Some of the energy from dc source V_{in} transfer to the secondary side of the coupled inductor to charge the capacitor C_3 . The switched capacitor C_b is charged by the LC series circuit.

D. Mode III [t2, t3]

During this interval, the switch S is turned OFF at t_2 . Diodes D_1 and D_4 are still forward biased; diodes D_2 and D_3 are reverse biased. The path of current flow is shown in Fig. 5(c). The magnetizing current and LC series current charge the parasitic capacitor C_o of the MOSFET.

E. Mode IV [t3, t4]

During this interval, S is still in the turnoff state. The diodes D_1 , D_2 , and D_4 are forward biased. The diode D_3 is reverse biased. The current-flow path is shown in Fig. 5(d). The current i_{d4} charges the output capacitor C_3 and decreases linearly. The total voltage of $V_{in} + V_{Lm} + V_{Cb}$ is charging to clamped capacitor C_1 , and some of the energy is supplied to the load.

F. Mode V [t4, t5]

During this interval, switch S is still in the turn-off state. The diodes D_1 and D_4 are turned OFF; the diodes D_2 and D_3 are forward biased. The current-flow path is shown in Fig. 5(e). The energy of the primary side still charges to the clamped capacitor C_1 and supplies energy to the load [5]. Some of the energy from dc source V_{in} is transferred to the secondary side of the coupled inductor to charge the capacitor C_2 , and the current i_{d3} increases linearly.

G. Mode VI [t5, t6]

During this interval, switch S is still in the turn-off state. The diodes D_1 , D_2 , and D_4 are reverse biased; the diode D_3 is forward biased. The current-flow path is shown in Fig. 5(f). The current i_{Lk1} is dropped till zero [9]. The magnetizing inductor L_m continuously transfers energy to the third leakage inductor L_{k3} and the capacitor C_2 . The energies are discharged from C_1 and C_3 to the load. The current i_{d3} charges C_2 and supplies the load current.

4. Simulation diagram

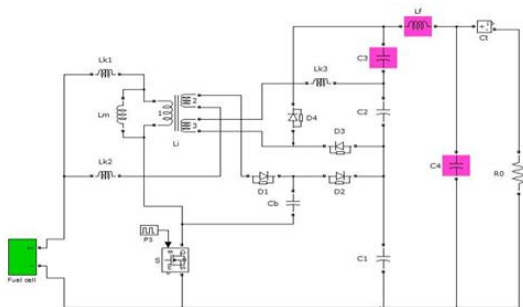

Fig. 4. Simulation circuit

5. Simulation results

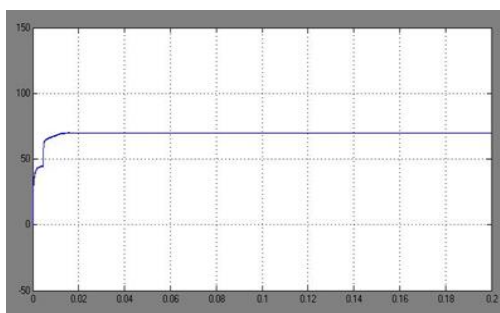

Fig. 5. Fuel cell output voltage

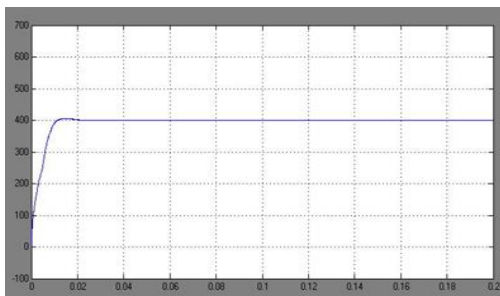

Fig. 6. Output voltage

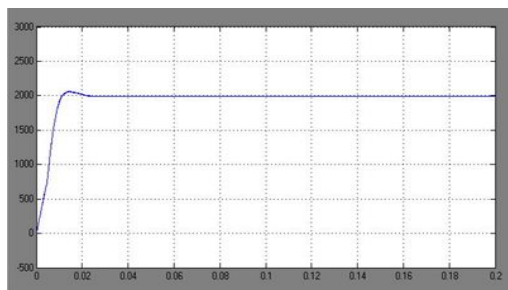

Fig. 7. Output power

6. Conclusion

In this paper, a high step-up dc-dc converter for fuel cell hydroid electric vehicle applications is clearly analyzed and successfully verified. By using technologies of three-winding coupled inductor, switched capacitor, and voltage doubler

circuit, the high step-up conversion can be efficiently obtained. The leakage energy is recycled and large voltage spike is alleviated; thus, the voltage stress is limited and the efficiency is improved. The full-load efficiency is up to 91.32% and the maximum efficiency is up to 96.81%. The voltage stress on the main switch is clamped as 120 V at D_{max} . The low-voltage-rated switch with low RDS-ON can be selected for the reduction of conduction losses. Thus, the proposed converter is suitable for high-power applications as fuel cell systems in hydroid electric vehicles.

References

- [1] W. Li, X. Lv, Y. Deng, J. Liu, and X. He, "A review of non-isolated high step-up DC/DC converters in renewable energy applications," in Proc. IEEE Appl. Power Electron. Conf. Expo., Feb. 2009, pp. 364–369.
- [2] W. Li and X. He, "Review of nonisolated high-step-up DC/DC converters in photovoltaic grid-connected applications," IEEE Trans. Ind. Electron., vol. 58, no. 4, pp. 1239–1250, Apr. 2011.
- [3] M. A. Laughton, "Fuel cells," IEE Eng. Sci. Edu. J., vol. 11, no. 1, pp. 7–16, Feb. 2002.
- [4] W. Jiang and B. Fahimi, "Active current sharing and source management in fuel cell-battery hybrid power system," IEEE Trans. Ind. Electron., vol. 57, no. 2, pp. 752–761, Feb. 2010.
- [5] P. Thounthong, S. Rael, and B. Davat, "Analysis of supercapacitor as second source based on fuel cell power generation," IEEE Trans. Ind. Electron., vol. 24, no. 1, pp. 247–255, Mar. 2009.
- [6] Khaligh and Z. Li, "Battery, ultra-capacitor, fuel cell, and hybrid energy storage systems for electric, hybrid electric, fuel cell, and plug-in energy source applications: State of the art," IEEE Trans. Veh. Technol., vol. 59, no. 6, pp. 2806–2814, Jul. 2010.
- [7] L. Wang and H. Li, "Maximum fuel economy-oriented power management design for a fuel cell vehicle using battery and ultra-capacitor," IEEE Trans. Ind. Appl., vol. 46, no. 3, pp. 1011–1020, May/June. 2010.
- [8] M. Marchesoni and C. Vacca, "New DC-DC converter for energy storage system interfacing in fuel cell energy."