

# Regulation of Unbalanced Voltages and Currents in 3-Phase Transmission Systems by using Distributed Power Flow Controller (DPFC)

Yamini Sivani Hyndhavi Amaravathi<sup>1</sup>, K. Satish Kumar<sup>2</sup>, A. Yadunanda Kumar<sup>3</sup>

<sup>1</sup>PG Scholar, Dept. of Electrical and Electronics Engineering, Brahmaiah College of Engg., Nellore, India

<sup>2,3</sup>Assistant Professor, Dept. of Electrical and Electronics Engg., Brahmaiah College of Engg., Nellore, India

**Abstract:** Distributed Power Flow Controller (DPFC) to compensate unbalanced 3-phase-currents in transmissions systems is made out of a Unified Power Flow Controller is another gadget inside the group of FACTS. The DPFC has similar control ability as the UPFC, yet with much lower cost and higher dependability. This task tends to one of the uses of the DPFC in particular pay of uneven flows in transmission frameworks. Since the series-converters of the DPFC are single stage, the DPFC can repay both dynamic and receptive, zero and negative grouping uneven flows. To remunerate the unbalance, two extra current controllers are enhanced to control the zero and negative sequence-currents separately. In this paper, open-loop DPFC system with disturbance and closed-loop DPFC systems with PI and Hysteresis controllers are modeled and simulated using MATLAB/SIMULINK.

**Keywords:** FACTS, UPFC, DPFC, STATCOM, SSSC, Voltage Source Converter (VSC)

## 1. Introduction

Power has assumed an inexorably essential job in our everyday lives, with a sensational increment in utilization just as the generation of power in the course of recent years. The electrical power framework serves to convey electrical energy to buyers. An electrical power framework manages electrical generation, transmission, dispersion and utilization. The FACTS technology is the application of power electronics in transmission systems [1]. The static Compensator (STATCOM) is a shunt connected gadget that is able to provide reactive power support at a network location far away from the generators [2]. “The Unified Power Flow Controller (UPFC) is comprised of a STATCOM & a SSSC” [3], coupled via a common DC link to allow “bi directional flow of active power between the series yield terminals of the SSSC & the shunt yield terminals of the STATCOM” [4]. Distributed FACTS (D FACTS) [5] is another approach to understand cost effective power flow control. A new concept for power flow control is by distributed UPFC [6]. The system, called distributed power flow controller (DPFC), consists of several low power series converters and one shunt large power converter without

common dc link. Also new is that the power exchange between the shunt and series parts is through the existing transmission line at a harmonic frequency. This solution enables the DPFC to fully control all power system parameters, and it reduces the cost and increases the reliability of device at the same time. The PQ issues like voltage varieties and flow varieties displayed in the electrical systems are because of the buyer's utilities. To beat this issue, a conveyed power stream controller was introduced [6]. DPFC to enhance the power nature of 33 bus radial framework was proposed [7]. Effect of DPFC to enhance PQ dependent on synchronous reference outline technique was introduced [8]. The structure and execution of new DPFC to PQ is shown in [9]. This DPFC strategy is same as the UPFC used to remunerate the voltage list and the current ripple. In DPFC, it takes out the normal dc link capacitor and rather than single three phase series converter it has three individual single stage converters. This DPFC can be able to work even with the series converter failures [10] and shunt converter failures [11]. The advancements in DPFC are introduced in [12]. This introduced framework uses conveyed power stream controllers and adaptable power from basic networks. So as to disentangle the DPFC and concentrate its outer attributes, the working standard and topology of the DPFC are broke down, and the third consonant current is taken as the scaffold of energy trade on the series parallel side. At that point the double circle decoupling control procedure of the DPFC [13], just as its proportionate numerical model is built up, and subsequently understanding the free control of both dynamic and reactive power streams for the power transmission line. The DPFC Flow chart and configuration are shown in Fig. 1 and Fig. 2 respectively.

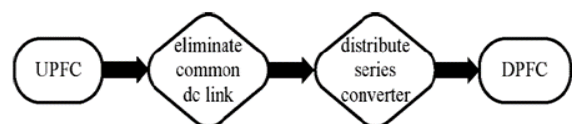

Fig. 1. Flow chart from UPFC to DPFC

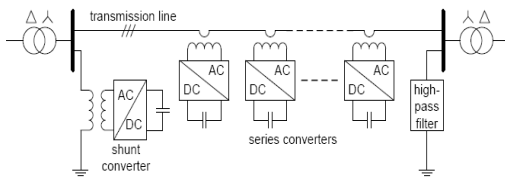

Fig. 2. DPFC Configuration

## 2. Operating principle of DPFC

### A. Active power exchange with eliminated DC link

Inside the DPFC, the transmission line introduces a typical association between the AC ports of the shunt & the series converters. In this way, it is able to trade dynamic power through the AC ports. The technique depends on power hypothesis of non-sinusoidal parts. As indicated by the ‘Fourier analysis’, non-sinusoidal voltage and current can be communicated as the entirety of sinusoidal capacities in various frequencies with various amplitudes. Since the integrals of the entire cross result of terms with various frequencies are zero, the dynamic power can be communicated by:

$$P = \sum_{i=1}^{\infty} V_i I_i \cos \Phi_i \quad (1)$$

Where, ‘ $V_i$  and  $I_i$ ’ are the –voltage & current at the  $i^{\text{th}}$  harmonic frequency respectively, and  $\Phi_i$  is the ‘comparing angle between the voltage & current’. From equation (1), the dynamic forces at various frequencies are free from one another and the voltage or current at one frequency has no effect on the dynamic power at different frequencies. The autonomy of the dynamic power at various frequencies gives the likelihood that a converter without a power source can create dynamic power at one recurrence and retain this power from different frequencies. By applying this strategy to the DPFC, the shunt converter can retain dynamic power from the network at the essential recurrence and infuse the power back at a symphonious recurrence. This symphonious dynamic power courses through a transmission line outfitted with series converters. As indicated by the measure of required dynamic power at the crucial recurrence, the DPFC SC produce a voltage at the consonant recurrence, in this way engrossing the dynamic power from symphonious segments. Ignoring misfortunes, the dynamic influence produced at the essential recurrence is equivalent to the influence consumed at the consonant recurrence.

### B. Using third harmonic components

Because of the interesting highlights of third consonant recurrence parts in a three stage framework, the third symphonious is chosen for dynamic power trade in the DPFC. In a three stage framework, the third symphonious in each stage is indistinguishable, which implies they are ‘zero arrangement’ parts. Since the zero grouping symphonious can be normally obstructed by Y- $\Delta$  transformers and these are generally consolidated in power frameworks (as a method for evolving

voltage), there is no additional channel required to counteract consonant spillage. As presented over, a high pass channel is required to make a closed loop for the consonant current and the cutoff recurrence of this channel is roughly the essential recurrence. Since the voltage confinement is high and the symphonious recurrence is near the cutoff recurrence, the channel will be exorbitant. By utilizing the zero arrangement symphonious, the expensive channel can be supplanted by a link that interfaces the unbiased purpose of the Y- $\Delta$  transformer on the right side with the ground. Since the  $\Delta$  winding seems open circuit to the third consonant current, all symphonious current will course through the Y- $\Delta$  winding and concentrate to the establishing link. In this manner, the huge high pass filter is dispensed with.

### C. Advantages of DPFC

The DPFC can be considered as an UPFC that utilizes the D-FACTS idea and the idea of trading power through consonant. In this way, the DPFC acquires every one of the benefits of the UPFC and the D-FACTS, which are as per the following.

- 1) High control capacity
- 2) High dependability
- 3) Low cost
- 4) Low Harmonic distortion

## 3. Simulation Results

Circuit diagram of open loop DPFC system with disturbance is delineated in Fig. 3.

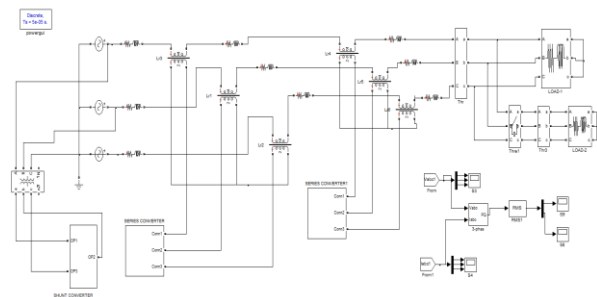

Fig. 3. Simulink diagram

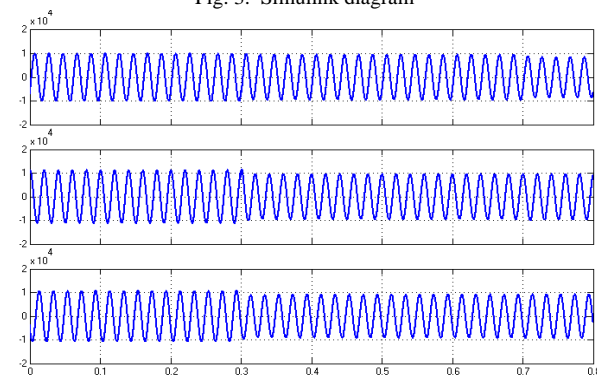

Fig. 4. Voltage at Bus-2

Voltage at bus-2 is delineated in Fig. 4 and the value is

$0.8 \times 10^4$  V. Current at bus-2 is delineated in Fig. 5 and the value is 26 A. Real power at bus-2 is delineated in Fig. 6 and the value is  $3.4 \times 10^5$  MW. Reactive power at bus-2 is delineated in Fig. 7 and the value is  $1.3 \times 10^5$  MVAR.

$V_R$

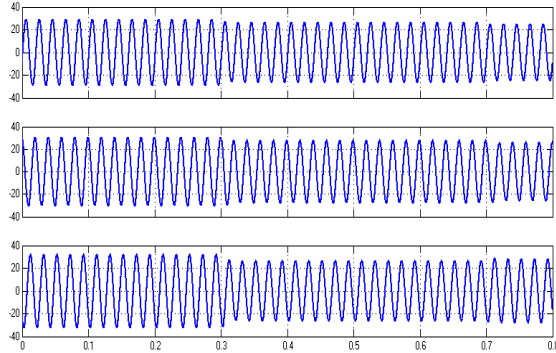

Fig. 5. Current at Bus-2

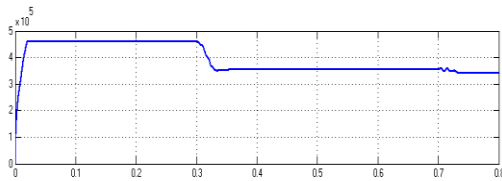

Fig. 6. Real power at Bus-2

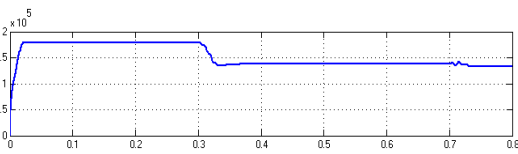

Fig. 7. Reactive power at Bus-2

Circuit diagram of closed loop DPFC system with PI controller is delineated in Fig. 8.

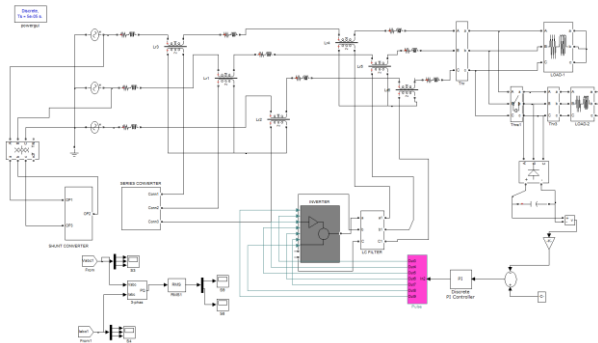

Fig. 8. Circuit diagram of closed loop DPFC system with PI controller

Voltage at bus-2 is delineated in Fig. 9 and the value is  $1.2 \times 10^4$  V. Current at bus-2 is delineated in Fig. 10 and the value is 30 A.

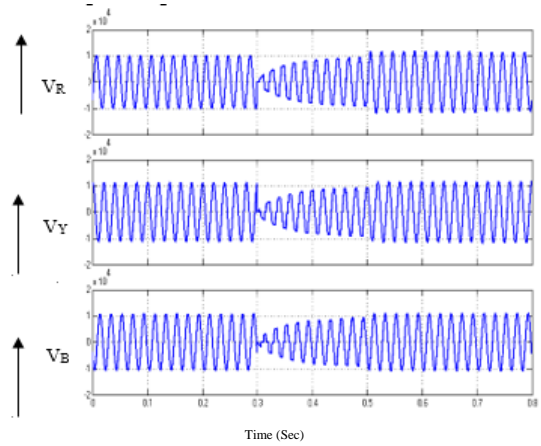

Fig. 9. Voltage at Bus-2

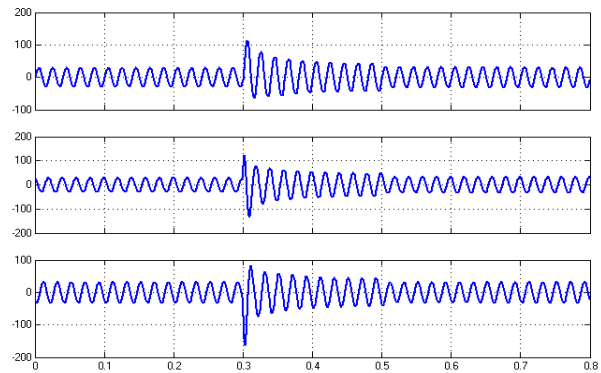

Fig. 10. Current at Bus-2

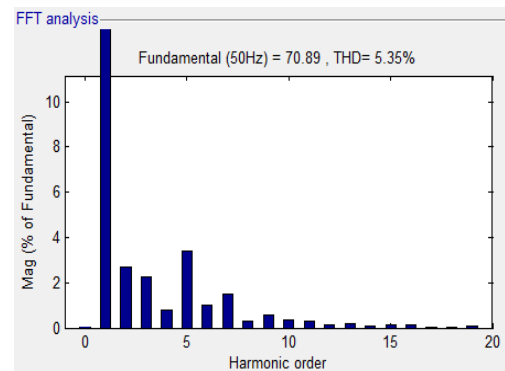

Fig. 11. FFT analysis

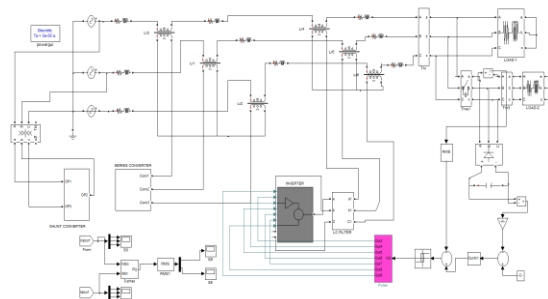

Fig. 12. Simulink diagram

Current THD is delineated in Fig. 13. Real power is delineated in Fig. 14 and the value is  $4.8 \times 10^5$  MW. Reactive

power is delineated in Fig. 14 and the value is  $1.8 \times 10^5$  MVAR.

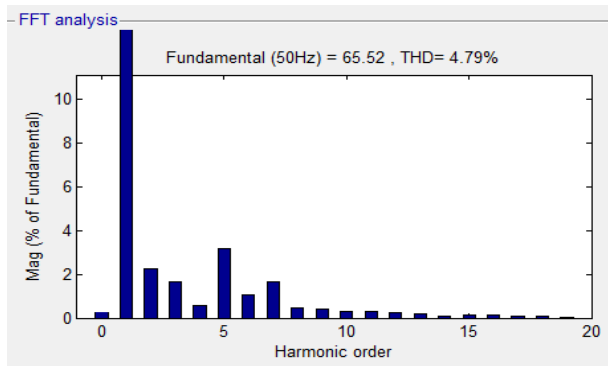

Fig. 13. Current THD

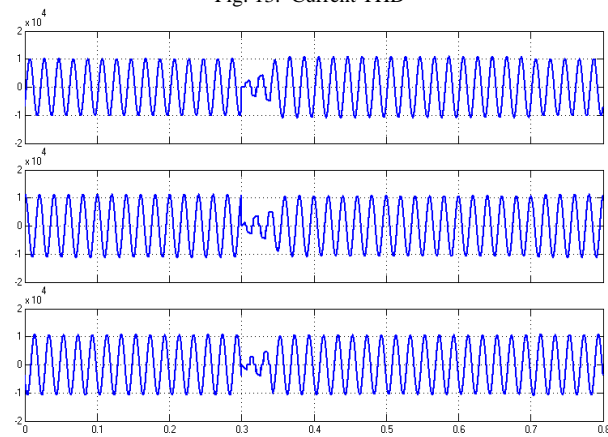

Fig. 14. Reactive power

#### 4. Conclusions and Future Scope

DPFC systems controlled by PI and Hysteresis Controllers were designed, modeled and ‘simulated using MATLAB Simulink’. The ‘simulation results of open loop and closed loop systems’ were presented. The proposed reactive power loop was successfully employed to ‘maintain constant’ reactive power. The response of Hysteresis Controller controlled system was found to be superior to the ‘PI controlled system’. This was due to reduction in the peak time, the peak ‘overshoot and the

steady state error’. The ‘advantages of DPFC’ are improved voltage and reactive power profiles. The disadvantage of DPFC is the requirement of about six inverters, six driver circuits and ‘injection transformers’.

#### References

- [1] J. Faiz, G. H. Shahgholian, and M. Torabian, “Design and simulation of UPFC for enhancement of PQ in transmission lines,” IEEE International Conference on Power System Technology, vol. 24, no. 4, 2010.
- [2] E. Emanuel and J. A. McNeill, “Electric power quality,” Annu. Rev. Energy Environ, 1997.
- [3] N. R. Patne and K. L. Thakre, “Factor affecting characteristics of – VOLTAGE sag due to fault in the power system,” Serbian Journal of Electrical engineering, Vol 5, no 1, 2008.
- [4] R. Enslin, “Unified approach to power quality mitigation,” in Proc. IEEE Int. Symp. ‘IE’ (ISIE 98), vol. 1, 1998.
- [5] D. Divan and H. Johal, “Distributed FACTS a new concept for realizing grid power flow control,” in Power Electronics Specialists Conference, 2005. PESC ‘05. IEEE 36th, 2005, pp. 8–14.
- [6] V. Anantha Lakshmi and R. Jyothsna, “Mitigation of voltage and current variations due to 3 phase fault in a single machine system using DPFC,” 2016 International Conference on Electrical, Electronics, and Optimization Techniques (ICEEOT), 2016.
- [7] S. Vadivel, and B. Baskaran, “Distributed Power Flow Controller (DP FC) to Improve the Power Quality of 33 Bus Radial System”, International Journal of Engineering Inventions, vol. 5, no. 10, pp. 31-44, November 2016.
- [8] Ahmad Jamshidi, S. Masoud Barakati, and M. Moradi Ghahderijani, “Impact of Distributed Power Flow Controller to Improve Power Quality Based on Synchronous Reference Frame Method,” IACSIT ‘International Journal of Engineering and Technology, vol. 4, no. 5, October 2012.
- [9] K. S. Srikanth, “Design and Implementation of New DPFC to Control Power Quality,” Int. J. Chem. Sci., vol. 14, no. 4, pp. 2066-2074, 2016.
- [10] Z. Yuan, S. W. H. De Haan, and B. Ferreira, “Control Scheme to improve DPFC performance during series converter failures,” in power electronics conference 2010.
- [11] Sjoerd W. H. De Haan, et. al, “DPFC Control during Shunt Converter Failure,” in IEEE Energy Conversion Congress and Exposition, 2009.
- [12] Oliver Pohl, Florian Rewald, Stefan Dalhues, Pascal Jörke Christian Rehtanz, Christian Wietfeld, Andreas Kubis, Ruben Kentchim Tamgue, and Detlev Kirsten, “Advancements in Distributed Power Flow Control,” 53rd International Universities Power Engineering Conference UPEC, Sept. 2018.
- [13] Meng Wu, Aihong Tang, Zengbao Wang, Xu Zheng, and Qiushi Xu, “Study on an Exact Equivalent Model of DPFC,” IEEE 3rd Advanced Information Technology Electronic and Automation Control Conference, (IAEAC), pp. 2626–2629, Oct. 2018.